



tarifs 2023

notification :

compte tenu des aléas liés aux augmentations imprévues, les prix 2023 seront systématiquement vérifiés pour chaque produit lors d'une demande de devis



COMARTEX
Depuis
1980



des solutions multiples...



tarifs 2023 tous les prix sont hors taxes départ usine talie hors outils hors mise en service

comartex tél 00 33 1 45 76 53 03

comartex@comartex.











MANTA ED 50

IT
Robusta, precisa, versatile ed economica, adatta a tutti quei materiali che si trovano nel cantiere edile. È dotata di pompa sommersa situata all'interno del basamento per il recupero dell'acqua di raffreddamento del disco e di testa inclinabile per tagli a 45°. **ACCESSORI:** Maniglie e ruote di trasporto; Set chiavi (in dotazione). **OPZIONALI:** Disco diamantato.

EN
Rugged and inexpensive Chop Saw guaranteeing an accurate cutting. Being extremely versatile, it is suitable to process all materials used by the builder's yards. It is equipped with a submersible pump placed inside the base to collect the water cooling the blade and with a tilting head for 45° cuts. **ACCESSORIES:** transport handles and wheels; set of servicing wrenches. **OPTIONALS:** Diamond cutting blade.

FR
Débiteuse solide, précise, polyvalente et économique adaptée à tous les matériaux qui se trouvent sur les chantiers de construction. Elle est pourvue d'une pompe submergée placée dans sa base et qui permet de récupérer l'eau de refroidissement du disque. Tête inclinable pour des coupes à 45°. **ACCESSOIRES:** Poignée et roues de transport; Jeu de clés. **EN OPTION:** Disque diamant.

ARTICOLO ITEM ARTICLE	MOD	 mm	 RPM	 kW - Volt	 mm	 mm	 mm	 cm (L-B-H)	 Kg	PREZZO PRICE PRIX €
120100	MANTA ED 50	350-25,4	2800	2.2 - 230	600	210	100	112x64x64	81	1.730,00
120102	MANTA ED 50 - 400	400-25,4	2800	2.2 - 230	600	210	130	114x64x64	81	1.800,00
120103	MANTA ED 50 - 450	450-25,4	2800	3 - 400	600	210	150	114x64x78	81	1.860,00











MANTA ED 50-600-700

IT
Robusta, precisa, versatile ed economica, adatta a tutti quei materiali che si trovano nel cantiere edile. È dotata di pompa sommersa situata all'interno del basamento per il recupero dell'acqua di raffreddamento per il disco. Basamento in ferro verniciato; banco di lavoro scorrevole in ferro verniciato; testa basculante; gambe pieghevoli; barre stabilizzanti **ACCESSORI:** Squadra diagonale; Set di chiavi di servizio; **OPZIONALI:** Disco diamantato; Ruote di movimentazione macchina.

EN
Economical heavy-duty cutting machine having an accurate operation. Being absolutely versatile, it is suitable to process all materials by the builder's yard. It is equipped with a submersible pump placed inside the base for the water collection cooling the blade. Base frame in painted steel; sliding working table in painted steel; folding legs; stabilizing bars **ACCESSORIES:** Diagonal square; Set of servicing wrenches. **OPTIONALS:** Diamond blade; Wheels.

FR
Débiteuse solide, précise, polyvalente et économique adaptée à tous les matériaux qui se trouvent sur les chantiers de construction. Elle est pourvue d'une pompe submergée placée dans sa base et qui permet de récupérer l'eau de refroidissement du disque. Base en fer vernie; Banc de travail coulissant; Jambes pliables; Barres stabilisantes. **ACCESSOIRES:** Equerre diagonale; Jeu de clés. **EN OPTION:** Disque diamant; Roues.

ARTICOLO ITEM ARTICLE	MOD	 mm	 RPM	 kW - Volt	 mm	 mm	 mm	 cm (L-B-H)	 Kg	PREZZO PRICE PRIX €
120163	MANTA ED 50-600 trifase	600 - 30	1400	4 - 400	400	330	230	123x61,5x145	89	2.600,00
120171	MANTA ED 50-600 monofase	600 - 30	1400	2.2 - 230	400	330	230	123x61,5x145	89	2.600,00
120174	MANTA ED 50-700 monofase	700 - 30	1400	2.2 - 230	420	330	280	123x62x145	100	2.900,00
120175	MANTA ED 50-700 trifase	700 - 30	1400	4 - 400	420	330	280	123x62x145	100	2.900,00

MANTA TP



IT

Robusta, precisa, versatile ed economica adatta a tutti quei materiali che si trovano nel cantiere edile. È dotata di pompa sommersa situata all'interno del basamento per il recupero dell'acqua di raffreddamento per il disco. Struttura e banco in ferro verniciato; scorrimento del banco di lavoro tramite spintore a maniglia; gambe con ruote.

ACCESSORI: Ruote; Set chiavi di servizio.

OPZIONALI: Disco diamantato.

EN

Economical heavy-duty cutting machine having an accurate operation. Being absolutely versatile, it is suitable to process all materials by the builder's yard. It is equipped with a submersible pump placed inside the base for the water collection cooling the blade. Base frame in painted steel; bench travel by means of a push handle; legs with wheels.

ACCESSORIES: Wheels; Set of servicing wrenches.









OPTIONALS: Diamond blade.

FR

Débiteuse solide, précise, polyvalente et économique adaptée à tous les matériaux qui se trouvent sur les chantiers de construction. Elle est pourvue d'une pompe submergée placée dans sa base et qui permet de récupérer l'eau de refroidissement du disque. Base en fer vernie; banc de travail coulissant au moyen d'une grosse poignée; jambes avec roues.

ACCESSOIRES: Roues; Jeu de clés de service.

EN OPTION: Disque diamant.

ARTICOLO ITEM ARTICLE	MOD	 mm	 RPM	 kW - Volt	 mm	 mm	 mm	 cm (L-B-H)	 Kg	PREZZO PRICE PRIX €
130227ED	MANTA TP 650 monofase	650 - 30	1400	2.2 - 230	600	440	250	165x95x138	240	3.650,00
130220ED	MANTA TP 650	650 - 30	1400	4 - 400	600	440	250	165x95x138	240	3.360,00
130221ED	MANTA TP 750 monofase	750 - 40	900	2.6 - 230	530	440	300	165x95x142	260	4.190,00
130222ED	MANTA TP 750	750 - 40	1400	4 - 400	530	440	300	165x95x142	255	3.580,00
130223ED	MANTA TP 800	800 - 40	1400	5,5 - 400	500	440	325	165x95x142	260	3.750,00
130224ED	MANTA TP 1000*	1000 - 60	900	7,5 - 400	450	410	400	165x95x152	310	5.340,00

*IT motore autofrenante *EN Self-braking motor *FR Moteur freiné



MANTA ED 65-85-100-120-150

IT









Robusta ed economica. Veramente precisa con scorrimento della testa tramite cuscinetti lineari a ricircolo su sfere su due barre cromate e rettificate. È dotata di pompa sommersa situata all'interno del basamento per il recupero dell'acqua di raffreddamento del disco. Moto verticale della testa tramite volantino per una regolazione stabile e veloce. Testa inclinabile per tagli a 45°. **ACCESSORI:** Set chiavi di servizio; Pompa. **OPZIONALI:** Disco taglio; Battuta laterale; Squadra diagonale; Estensore; Ruote di trasporto.

EN

Rugged and inexpensive machine guaranteeing an extremely accurate cutting. Head sliding on two chromium-plated and ground bars by means of linear ball-bearings. It is equipped with a submersible pump placed inside the base to collect the water cooling the blade. Vertical head motion by means of a handwheel for a fast and stable adjustment. Tilting head for 45° cuts. **ACCESSORIES:** 1 submersible pump; set of servicing wrenches. **OPTIONALS:** diamond cutting blade; side stop; diagonal square; side table; wheels.

FR

Robuste, précise, polyvalente et économique. Vraiment précise avec coulissement de la tête de sciage sur deux barres en acier chromées et rectifiées. Elle est équipée d'une pompe submergée située dans le banc pour la récupération de l'eau de refroidissement du disque. Mouvement vertical de la tête par volant pour un réglage stable et rapide. Tête inclinable pour des coupes à 45°. **ACCESSOIRES:** 1 pompe de récupération et renvoi eau; Jeu de clés. **EN OPTION:** Disque diamant; Butée latérale; équerre diagonale; Rallonge; Roues.

ARTICOLO ITEM ARTICLE	MOD	 mm	 RPM	 kW - Volt	 mm	 mm	 mm	 cm (L-B-H)	 Kg	PREZZO PRICE PRIX €
120150ED	MANTA 65	350 - 25,4	2800	2,2 - 230*	650	130	110	107x66x77	60	2.020,00
120200ED	MANTA 85	350 - 25,4	2800	2,2 - 230*	850	130	110	127x66x77	75	2.100,00
120250ED	MANTA 100	350 - 25,4	2800	2,2 - 230*	1000	130	110	140x66x77	90	2.180,00
120300ED	MANTA 120	350 - 25,4	2800	2,2 - 230*	1200	130	110	160x66x77	130	2.260,00
120350ED	MANTA 150	350 - 25,4	2800	2,2 - 230*	1500	130	110	197x66x77	140	2.480,00

*IT Disponibile anche in versione trifase - 3 kW. *EN 3 kW - triphase version is also available 3 kW. *FR Disponible triphasé.

MANTA EV



IT









Robusta, versatile ed economica. Veramente precisa con scorrimento della testa tramite cuscinetti lineari a ricircolo di sfere su due barre cromate e rettificate. È dotata di pompa sommersa situata all'interno del basamento per il recupero dell'acqua di raffreddamento del disco. Moto verticale della testa tramite volantino per una regolazione stabile e veloce. Testa inclinabile per tagli a 45°. **ACCESSORI:** Battuta; Set di chiavi di servizio; Squadra diagonale rotonda; Motore autofrenante. **OPZIONALI:** Squadra diagonale lunga; Battuta laterale; Estensore del banco in lamiera; Estensore del banco a rulli; Disco diamantato.

EN

Rugged, versatile and inexpensive machine with an extremely accurate cutting. The head slides on two chromium-plated ground bars by means of linear ball-bearings. It is equipped with a submersible pump placed inside the base to collect the water cooling the blade. Vertical head motion by means of a handwheel for a fast and stable adjustment. Tilting head for 45° cuts. **ACCESSORIES:** Stop; Set of servicing wrenches; Round squareself-braking motor. **OPTIONALS:** Long square; Side stop; Side table; Roller side table; Diamond cutting blade.

FR

Robuste, précise, polyvalente et économique. Vraiment précise avec coulissement de la tête de sciage sur deux barres en acier chromées et rectifiées. Elle est équipée d'une pompe submergée située dans le banc pour la récupération de l'eau de refroidissement du disque. Mouvement vertical de la tête par volant pour un réglage stable et rapide. Tête inclinable pour des coupes à 45°. **ACCESSOIRES:** Butée; Jeu de clés de service; Équerre ronde; Moteur freiné. **EN OPTION:** Équerre longue; Butée latérale; Rallonge; Disque diamant.

ARTICOLO ITEM ARTICLE	MOD	 mm	 RPM	 kW - Volt	 mm	 mm	 mm	 cm (L-B-H)	 Kg	PREZZO PRICE PRIX €
120206ED	MANTA EV 85-450	450 - 25,4	2800	2,6 - 230*	820	160	150	144x66x77	105	2.330,00
120256ED	MANTA EV 100-450	450 - 25,4	2800	2,6 - 230*	995	160	150	157x66x77	120	2.400,00
120308ED	MANTA EV 120-450	450 - 25,4	2800	2,6 - 230*	1150	160	150	177x66x77	160	2.480,00

*IT Disponibile anche in versione trifase - 3 kW. *EN 3 kW - triphase version is also available 3 kW. *FR Disponible triphasé.

MANTA KERF

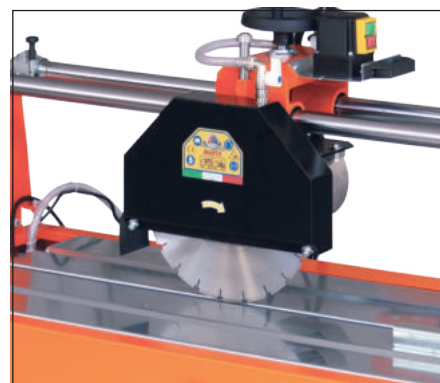

IT
Macchina pensata per il montaggio in cantiere delle pareti ventilate. Robusta, versatile ed economica. Veramente precisa, con scorrimento della testa tramite cuscinetti lineari a ricircolo di sfere su due barre cromate e rettificata. È dotata di pompa sommersa situata all'interno del basamento per il recupero dell'acqua di raffreddamento del disco. Moto verticale della testa tramite volantino per una regolazione stabile e veloce. Testa inclinabile per tagli a 45°. Possibilità di girare la testa di 180° ed utilizzando un supporto a corredo è possibile eseguire dei tagli sullo spessore per i materiali per pareti ventilate (max 60x60 cm).

ACCESSORI: Supporto Kerf; Battuta; Set di chiavi di servizio.

OPZIONALI: Disco diamantato; Laser a batteria.

EN
Machine designed for on-site assembly of ventilated walls. Rugged, versatile and inexpensive machine with an extremely accurate cutting. The head slides on two chromium-plated ground bars by means of linear ball-bearings. It is equipped with a submersible pump placed inside the base to collect the blade cooling water. Vertical head motion by means of a handwheel for a fast and stable adjustment. Tilting head for 45° cuts. Possibility to turn the head 180° and using a support supplied it is possible to make cuts on the thickness for the materials for ventilated walls (max 60x60 cm).









ACCESSORIES: Kerf Support; Stop; Set of servicing wrenches.

OPTIONALS: Diamond cutting blade; Battery laser.

FR
Machine conçue pour l'assemblage sur site de murs ventilés. Robuste, précise, polyvalente et économique. Vraiment précise avec coulissement de la tête de sciage sur deux barres chromées et rectifiées. Elle est équipée d'une pompe submergée située dans le banc pour la récupération de l'eau de refroidissement du disque. Mouvement vertical de la tête par volant pour un réglage stable et rapide. Tête inclinable pour des coupes à 45°. Possibilité de faire pivoter la tête à 180° et d'utiliser un support fourni pour couper l'épaisseur des matériaux des murs ventilés (max 60x60 cm).

ACCESSOIRES: Support Kerf; Butée; Jeu de clés de service.

EN OPTION: Disque Diamant; Laser à pile.

ARTICOLO ITEM ARTICLE	MOD	 mm	 RPM	 kW - Volt	 mm	 mm	 mm	 cm (L-B-H)	 Kg	PREZZO PRICE PRIX €
120230KERF	MANTA KERF 100	350 - 25,4	2800	2,2 - 230	1000	130	110	140x66x77	100	3.280,00

MANTA ED 120-150-200 SPECIAL



IT
Robusta, precisa, versatile ed economica. Estremamente precisa con scorrimento della testa tramite cuscinetti lineari a sfere su due barre cromate e rettificate. È dotata di una pompa sommersa all'interno della vasca per il recupero dell'acqua di raffreddamento del disco. Moto verticale della testa tramite un volantino. Testa inclinabile per tagli a 45°. Gambe ad angolo.

ACCESSORI: Battuta d'appoggio regolabile; Set di chiavi di servizio; Fori di sollevamento.

OPZIONALI: Disco diamantato; Battuta laterale; Squadra diagonale; Estensore del banco; Laser segnataglio.

EN
Rugged, precise, versatile and inexpensive machine with an extremely accurate cutting. The head slides on two chromium-plated ground bars by means of linear ball-bearings. It is equipped with a submersible pump placed inside the base to collect the water cooling the blade. Vertical head motion by means of a handwheel. Tilting head for 45° cuts; integrated angle legs.









ACCESSORIES: Adjustable stop; Set of servicing wrenches; Holes for the machine hoisting.

OPTIONALS: Diamond cutting blade; Side stop; Diagonal square; Side table; Battery laser pointer.

FR
Robuste, précise, polyvalente et économique. Vraiment précise avec coulisement de la tête de sciage sur deux barres en acier chromées et rectifiées. Elle est équipée d'une pompe submergée située dans le banc pour la récupération de l'eau de refroidissement du disque. Mouvement vertical de la tête par volant. Tête inclinable pour des coupes à 45°; jambes intégrées à angle.

ACCESSOIRES: Butée réglable; Jeu de clés de service; Trous à ceil de lavage.

EN OPTION: Disque diamant; Butée latérale; équerre; Rallonge; Laser marque coupe.

ARTICOLO ITEM ARTICLE	MOD	 mm	 RPM	 kW - Volt	 mm	 mm	 mm	 cm (L-B-H)	 Kg	PREZZO PRICE PRIX €
120311	MANTA 120 SP	350 - 30	1400	2,2 - 230	1200	210	110	165x66x77	168	2.900,00
120301	MANTA 120 SP	350 - 30	1400	4 - 400	1200	210	110	165x66x77	168	2.970,00
120305	MANTA 120 SP	450 - 30	2800	4 - 400	1200	210	150	165x66x77	168	2.890,00
120335	MANTA 150 SP	450 - 30	1400	2,2 - 230	1500	210	150	197x88x77	210	3.000,00
120356	MANTA 150 SP	350 - 25,4	2800	2,2 - 230	1500	210	150	197x88x77	210	2.910,00
120354ED	MANTA 150 SP	450 - 25,4	2800	3 - 400	1500	210	150	197x88x77	210	2.910,00
120400ED	MANTA 150 SP	450 - 30	2800	4 - 400	1500	210	150	197x88x77	216	3.000,00
120457	MANTA 200 SP	450 - 30	1400	2,2 - 230	2000	210	150	250x88x77	260	3.650,00
120458	MANTA 200 SP	350 - 25,4	2800	2,2 - 230	2000	210	150	250x88x77	260	3.600,00
120455	MANTA 200 SP	450 - 30	1400	4 - 400	2000	210	150	250x88x77	260	3.700,00
120451	MANTA 200 SP	450 - 30	2800	4 - 400	2000	210	150	250x88x77	260	3.700,00

IT Voltaggi e potenze a richiesta su tutti i modelli. *EN* Voltage and power on request on all models. *FR* Voltage et puissance sur demande.
IT Tutte le versioni montano barre cromate da 50 mm di diametro. *EN* All versions have chrome bars, 50 mm in diameter. *FR* Toutes les versions ont des barres chromées, 50 mm de diamètre.

Ø 40 mm



MANTA ALU BASIC 85-100-120-150

IT

Leggera, precisa e versatile realizzata in alluminio. Scorrimento della testa di taglio tramite cuscinetti lineari a ricircolo di sfere su due barre piene cromate e rettificate. È dotata di pompa sommersa situata all'interno del basamento che funge da vasca per il recupero dell'acqua di raffreddamento del disco. Salita e discesa della testa di taglio a mezzo volantino, avanzamento tramite apposita maniglia. Inclinazione a 45°. Gambe fisse provviste di barre stabilizzanti (eccetto il mod. 150). **ACCESSORI:** 1 squadra tonda per edilizia; 1 set di chiavi di servizio. **OPZIONALI:** disco di taglio; Battuta laterale; Squadra lunga; Estensore laterale; Ruote di movimentazione macchina; Laser segna-taglio a batteria.









EN

Light, precise and versatile machine made of aluminum. The head slides on two solid chromed and rectified steel bars by means of linear ball-bearings. Own self circulating water tank complete with pump. Head rise and fall by means of a handwheel, travel by means of a handgrip. 45° tilting head. Fixed legs with stabilizer bars (except mod. 150). **ACCESSORIES:** 1 square for masons; servicing wrenches. **OPTIONAL:** cutting blade; side stop; squaring bar; side table; wheels for an easy manoeuvring of the machine; battery laser pointer.

FR

Légère, précise, polyvalente, réalisée en aluminium. Coulisement de la tête de sciage sur deux barres en acier chromé et rectifié. Equipée de pompe pour la récupération et renvoi de l'eau de refroidissement du disque. Plongée de la tête de sciage au moyen d'un volant à manivelle; écoulement au moyen d'une poignée. Inclinaison à 45°. Pieds fixes avec barres stabilisantes (à exception du mod. 150). **ACCESSOIRES:** 1 équerre; jeu de clés de service. **EN OPTION:** disque de coupe; butée latérale; équerre; rallonge; roues; laser à batterie



ARTICOLO ITEM ARTICLE	MOD	 mm	 RPM	 kW - Volt	 mm	 mm	 mm	 cm (L-B-H)	 Kg	PREZZO PRICE PRIX €
120210AL	MANTA 85 ALU BASIC	350 - 25,4	2800	2,2 - 230	850	150	110	127x66x77	76	3.370,00
120254AL	MANTA 100 ALU BASIC	350 - 25,4	2800	2,2 - 230	1000	150	110	155x66x77	82	2.480,00
120311AL	MANTA 120 ALU BASIC	350 - 25,4	2800	2,2 - 230	1200	150	110	171x66x77	89	2.590,00
120363AL	MANTA 150 ALU BASIC	350 - 25,4	2800	2,2 - 230	1500	150	110	197x66x77	99	2.980,00

Ø 40 mm



MANTA ALLUMINIUM 65-85-100-120

IT

Leggera, precisa, versatile, costruita interamente in alluminio. Veramente precisa con scorrimento della testa tramite cuscinetti lineari a ricircolo di sfere su due barre cave cromate e rettificata. È dotata di pompa sommersa situata all'interno del basamento per il recupero dell'acqua di raffreddamento del disco. Moto verticale della testa tramite volantino per una regolazione stabile e veloce. Testa inclinabile per tagli a 45°. Gambe integrate e ripiegabili per facilitarne il trasporto; barre stabilizzanti. **ACCESSORI:** Battuta d'appoggio; Maniglie e ruote di trasporto; Set di chiavi di servizio; Squadra tonda; Estensore senza piede; Ruote di movimentazione macchina. **OPZIONALI:** Laser segna-taglio a batterie; Disco diamantato; Battuta laterale; Squadra diagonale lunga; Estensori aggiuntivi.









EN

Light and versatile Aluminium machine with an extremely accurate cutting. The head slides on two chromium-plated ground bars by means of linear ball-bearings. It is equipped with a submersible pump placed inside the base to collect the water cooling the blade. Vertical head motion by means of a handwheel for a fast and stable adjustment. Tilting head for 45° cuts. Provided with folding legs for an easy transport; Stabilizer bars. **ACCESSORIES:** Stop; Transport handles and wheels; Set of servicing wrenches; Round square; Side table without leg; Wheels to move the machine. **OPTIONALS:** Battery laser pointer; Diamond cutting blade; Side stop; Long square; Extra side table.

FR

Légère, précise, polyvalente, complètement construite en aluminium. Vraiment précise, avec coulissement de la tête de sciage sur deux barres en acier chromées et rectifiées. Elle est équipée d'une pompe submergée située dans le banc pour la récupération de l'eau de refroidissement du disque. Mouvement verticale de la tête par volant pour une réglage stable et rapide. Tête inclinable pour des coupes à 45°. Elle est équipée de jambes intégrées et repliables pour améliorer le transport; Barres stabilisantes. **ACCESSOIRES:** Butée; Poignée et roues de transport; Jeu de clés de service; Équerre ronde; Rallonge latérale sans pied; Roues. **EN OPTION:** Laser marque coupe à batterie; Disque diamant; Butée latérale; Équerre; Rallonge.



ARTICOLO ITEM ARTICLE	MOD	 mm	 RPM	 kW - Volt	 mm	 mm	 mm	 cm (L-B-H)	 Kg	PREZZO PRICE PRIX €
120150AL	MANTA 65 ALLUMINIUM	350 - 25,4	2800	2,2 - 230*	650	150	110	107x66x77	61	2.390,00
120200AL	MANTA 85 ALLUMINIUM	350 - 25,4	2800	2,2 - 230*	850	150	110	127x66x77	65	2.570,00
120250AL	MANTA 100 ALLUMINIUM	350 - 25,4	2800	2,2 - 230*	1000	150	110	155x66x77	72	2.710,00
120300AL	MANTA 120 ALLUMINIUM	350 - 25,4	2800	2,2 - 230*	1200	150	110	171x66x77	79	2.800,00

*IT Disponibile anche in versione trifase - 3 kW. *EN 3 kW - triphase version is also available. *FR 3 kW - Disponible triphase.



MANTA ALLUMINIUM 150-200

IT

Leggera, precisa, versatile, costruita interamente in alluminio. Veramente precisa con scorrimento della testa tramite cuscinetti lineari a ricircolo di sfere su due barre cave cromate e rettificate. È dotata di pompa sommersa situata all'interno del basamento per il recupero dell'acqua di raffreddamento per il disco. Moto verticale della testa tramite volantino per una regolazione stabile e veloce. Testa inclinabile per tagli a 45°. Gambe pieghevoli con ruote calzanti. **ACCESSORI:** Set di chiavi di servizio; Squadra tonda; Maniglie e ruote di trasporto; Estensore senza piede; Ruote di movimentazione macchina. **OPZIONALI:** Disco diamantato; Battuta laterale; Laser segna-taglio a batteria; Squadra lunga; Estensore del banco.









EN

Light, accurate, versatile, completely built in aluminium. Extremely accurate with head sliding by means of linear ball bearings on two chromed and rectified steel bars. It is equipped with a submersed pump inside the base to collect the water cooling the blade. Vertical head motion by means of a handwheel for a fast and stable adjustment. Tilting head for 45° cuts. Folding legs with wheels. **ACCESSORIES:** Set of servicing wrenches; Round square; Transport handles and wheels; Side table without leg; Wheels to move the machine. **OPTIONALS:** Diamond cutting blade; Side stop; Battery laser pointer; Long square; Side table.

FR

Légère, précise, polyvalente, complètement construite en aluminium. Vraiment précise, avec coulisement de la tête de sciage sur deux barres en acier chromées et rectifiées. Elle est équipée d'une pompe submergée située dans le banc pour la récupération de l'eau de refroidissement pour le disque. Mouvement verticale de la tête par volant pour une réglage stable et rapide. Tête inclinable pour des coupes à 45°. Jambes pliables avec roues. **ACCESSOIRES:** Jeu de clés de service; Équerre ronde; Poignées et roues de transport; Rallonge latérale sans pied; Roues de transport. **EN OPTION:** Disque diamant; Butée latérale; Laser marque coupe à batterie; Équerre diagonale longue; Rallonge.



ARTICOLO ITEM ARTICLE	MOD	 mm	 RPM	 kW - Volt	 mm	 mm	 mm	 cm (L-B-H)	 Kg	PREZZO PRICE PRIX €
120350AL	MANTA 150 ALLUMINIUM**	350-25.4	2800	2,2-230*	1500	150	110	197x66x77	89	2.980,00
120355AL	MANTA 150 ALLUMINIUM GRANIT**	350-30	1400	2,2-230*	1500	150	110	197x66x77	89	3.100,00
120354AL	MANTA 200 ALLUMINIUM	350-25.4	2800	2,2-230*	2000	150	110	250x88x77	106	3.800,00
120359AL	MANTA 200 ALLUMINIUM GRANIT	350-30	1400	2,2-230*	2000	150	110	250x88x77	106	3.900,00
120266AL	MANTA 200 ALLUM. LX GRANIT	450-40	1400	4-400	2000	150	150	275x88x81	136	4.600,00

*IT Disponibile anche in versione trifase. *EN Triphase version is also available. *FR Disponible triphasé. **IT Barre Ø 40 mm. **EN Bars Ø 40 mm. **FR Barres Ø 40 mm

MANTA INOX SERIES

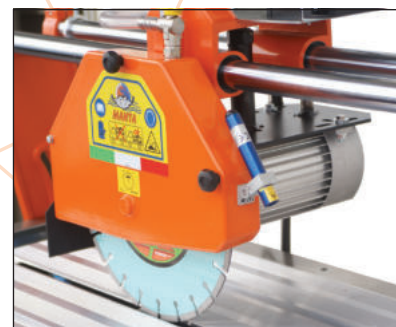

IT
Basamento in acciaio inox; Barre di scorrimento testa di taglio cromate e temprate, avanzamento della testa manuale tramite apposita maniglia, movimento verticale della testa a mezzo volante. Inclinazione della testa a 45°, gambe pieghevoli, barre stabilizzanti e motore auto frenante.

ACCESSORI: 1 pompa; 1 squadra tonda; 1 laser a batteria; Maniglie di trasporto con ruote; Ruote di movimentazione macchina (solo fino al modello 120); 1 Set chiavi di servizio.

OPZIONALI: disco; squadra lunga; battuta laterale; ruote di movimentazione macchina (Solo per mod. 150).

EN
Stainless steel base frame; Cutting head sliding on two chromed and hardened steel bars, manual head-travel by means of a handgrip, manual raise and fall by means of a handwheel, tilting head for 45 degree angle cuts, integrated folding legs, stabilizer bars, self-braking motor.









ACCESSORIES: 1 pump; 1 round square; 1 battery laser pointer; Transport handles and wheels; Wheels to move the machines (up to model 120); 1 set of servicing wrenches.

OPTIONALS: diamond cutting blade; wheels to move the machine (for mod. 150 only); long diagonal square; side stop.

FR
Base en acier inox; coulissement de la tête de sciage sur deux barres chromées et trempées; avancement de la tête de sciage au moyen d'une poignée; plongée manuelle au moyen d'un volant à manivelle; inclinaison de la tête de sciage pour coupes à 45°; jambes intégrées et repliables; barres stabilisantes; moteur avec frein.

ACCESSOIRES: 1 pompe; équerre ronde; Roues et poignées de transport; Roues (jusqu'au mod. 120); 1 laser marque coupe à batterie; Jeu de clés de service.

EN OPTION: Disque diamant; équerre longue; Butée latérale; Roues (seulement pour le mod. 150).

ARTICOLO ITEM ARTICLE	MOD	 mm	 RPM	 kW - Volt	 mm	 mm	 mm	 cm (L-B-H)	 Kg	PREZZO PRICE PRIX €
120261	MANTA 85 INOX	350 - 25,4	2800	2,6-230	850	160	110	144x66x77	96	3.220,00
120260	MANTA 100 INOX	350 - 25,4	2800	2,6-230	1000	160	110	157x66x77	106	3.340,00
120262	MANTA 120 INOX	350 - 25,4	2800	2,6-230	1200	160	110	177x66x77	120	3.700,00
120263	MANTA 150 INOX	350 - 25,4	2800	2,6-230	1500	160	110	197x66x77	166	3.900,00

IT Disponibile anche in versione trifase. EN Triphase version is also available. FR Disponible triphasé.. IT Motore autofrenante. EN Self-braking motor. FR Moteur freiné.

MANTA INOX KERAMIK

COPERTURA IN GOMMA
RUBBER COVERED
COUVERTURE EN CAOUTCHOUC

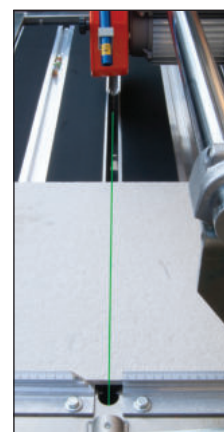

IT
Basamento in acciaio inox; barre di scorrimento testa di taglio cromate e temprate, avanzamento della testa manuale tramite apposita maniglia, movimento verticale della testa a mezzo volantino, inclinazione della testa a 45°, gambe pieghevoli, barre stabilizzanti. Regolazione del numero di giri del disco diamantato per un miglior rendimento in base al diametro del disco ed ai materiali da tagliare. Particolarmente indicata per il taglio dei nuovi materiali ceramici.

ACCESSORI: Pompa; Squadra diagonale; Estensore senza piede; Laser segna-taglio a batteria; Maniglie di trasporto con ruote; Set di chiavi di servizio.

OPZIONALI: Disco di taglio; Squadra lunga; Battuta laterale; Ruote di movimentazione macchina (Solo per mod. 150)

EN
Own self circulating water tank in stainless steel; chromium plated and hardened steel bars, head travel by means of a handle, head rise and fall manually operated by hand wheel, 45 degree angle cut, folding legs, stabilizer bars. RPM adjustment of the blade for a better performance of the machine according to the disk diameter and the materials to be cut. Particularly suitable for new ceramic material cutting.









ACCESSORIES: Water pump; square for masons; Side table without leg; battery laser pointer; handles and wheels for the machine hoisting; set of servicing wrenches.

OPTIONALS: Cutting blade; long squaring bar; side stop; wheels to facilitate the machine manoeuvring (mod. 150 only).

FR
Base en acier inoxydable; barre de déplacement de la tête de sciage au moyen d'une poignée, plongée au moyen d'un volant à manivelle, inclinaison de la tête à 45°, jambes repliables, barres de stabilisation. Réglage du nombre de révolutions du disque en diamant pour un meilleur rendement en fonction du diamètre du disque et des matériaux à couper. Convient particulièrement à la découpe de nouveaux matériaux céramiques.

ACCESSOIRES: Pompe; équerre diagonale; Rallonge sans pied; Laser marque coupe à batterie; Roues et poignées de transport; Jeu de clés de service.

EN OPTION: Disque diamant; équerre longue; Butée latérale; Roues (seulement pour le mod. 150).

ARTICOLO ITEM ARTICLE	MOD	 mm	 RPM	 kW - Volt	 mm	 mm	 mm	 cm (L-B-H)	 Kg	PREZZO PRICE PRIX €
120296	MANTA INOX 100 KERAMIK	350 - 25,4	1200/4200*	2,2-230	1000	135	110	157x66x77	111	4.070,00
120294	MANTA INOX 120 KERAMIK	350 - 25,4	1200/4200*	2,2-230	1200	135	110	177x66x85	125	4.200,00
120297	MANTA INOX 150 KERAMIK	350 - 25,4	1200/4200*	2,2-230	1500	135	110	197x66x77	171	4.490,00

*IT Regolazione giri motore disco. *EN Disc motor speed adjustment. *FR Réglage de la vitesse du moteur du disque.



MANTA INOX 120-150-200 LX

IT









Basamento in acciaio inox; barre di scorrimento testa di taglio cromate e temprate, avanzamento della testa tramite riduttore e volantino. Movimento verticale della testa manuale, inclinazione della testa a 45° manuale; Gambe angolari. **ACCESSORI:** Set chiavi di servizio, 1 pompa; laser segna-taglio a batteria; 1 estensore a rulli; 1 battuta laterale; 1 squadra tonda. **OPZIONALI:** Disco di taglio; Squadra lunga; Estensori a rulli aggiuntivi; Squadra meccanica.

EN

Stainless steel base frame; cutting head sliding on two chromed and hardened steel bars; manual head travel; manual rise and fall by means of a handwheel; tilting head for 45° angle cuts; angle legs. **ACCESSORIES:** 1 water pump; Battery laser pointer; 1 side roller table; 1 side stop; 1 round square; Set of servicing wrenches. **OPTIONALS:** Extra side tables; Mechanic square; Blade for granite and natural stones; Blade for marble; Long Diagonal Square.

FR

Base en acier inox; coulissement de la tête de sciage sur deux barres chromées et trempées; avancement de la tête de sciage au moyen d'un réducteur et d'un volant à manivelle; plongée manuelle; inclinaison manuelle de la tête de sciage pour coupes à 45°; Jambes à angle. **ACCESSOIRES:** 1 pompe à eau; Laser à batterie; 1 rallonge à rouleaux; 1 butée latérale; 1 équerre ronde; Jeu de clés de service. **EN OPTION:** Disque de coupe; équerre longue; Rallonges supplémentaires; équerre mécanique.

ARTICOLO ITEM ARTICLE	MOD	 mm	 RPM	 kW - Volt	 mm	 mm	 mm	 cm (L-B-H)	 Kg	PREZZO PRICE PRIX €
120282	MANTA INOX 120 LX*	350 - 25,4	2800	2,6 - 230	1200	180	110	195x66x87	190	4.800,00
120279	MANTA INOX 150 LX	450 - 30	2800	4 - 400	1500	180	150	218x66x87	190	5.300,00
120265	MANTA INOX 150 LX GRANIT	450 - 30	1400	2,2 - 230	1500	180	150	218x66x87	220	5.400,00
120281	MANTA INOX 150 LX GRANIT	450 - 40	1400	4 - 400	1500	180	150	218x66x87	220	5.530,00
120264	MANTA INOX 200 LX*	350 - 25,4	2800	2,6 - 230	2000	180	110	275x66x87	240	5.800,00
120268	MANTA INOX 200 LX GRANIT	450 - 30	1400	2,2 - 230	2000	180	150	275x66x87	250	5.930,00
120278	MANTA INOX 200 LX GRANIT	450 - 40	1400	5,5 - 400	2000	180	150	275x66x87	250	6.100,00

**IT Motore autofrenante. *EN Self-braking motor. *FR Moteur freiné.*

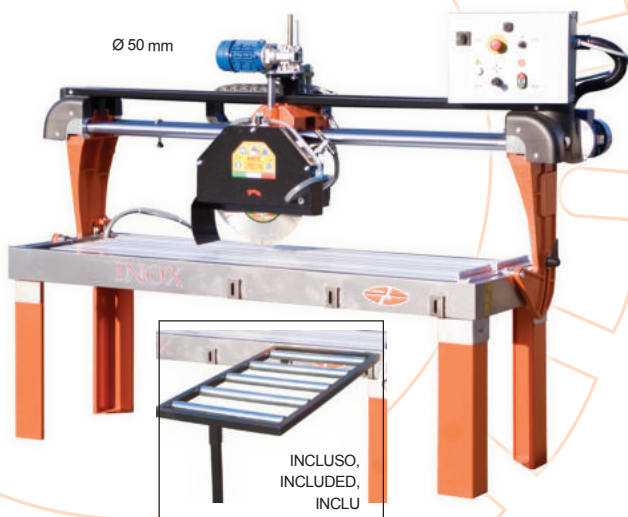

MANTA INOX 120-150-200 LX SA PLUS

IT









Basamento in acciaio inox; barre di scorrimento testa di taglio cromate e temprate; avanzamento e movimento verticale della testa motorizzati con velocità regolabile; inclinazione della testa a 45°; gambe angolari. **ACCESSORI:** Pompa; Laser a batteria; Estensore a rulli; Battuta laterale; Squadra tonda; Set di chiavi di servizio. **OPZIONALI:** Disco di taglio; Squadra lunga; Estensori a rulli aggiuntivi; Mole; Squadra meccanica.

EN

Stainless steel base frame; cutting head sliding on two chromed and hardened steel bars; motorized cutting head with adjustable speed; motorized head raise and fall; tilting head for 45 degree angle cuts; angle legs. **ACCESSORI:** Pump; Battery laser pointer; Side roller table; Side stop; Round square; Set of servicing wrenches. **OPZIONALE:** Cutting blade; Long Square; Extra side tables; Grinding wheels; Mechanic square.

FR

Châssis en acier inox; coulissement de la tête de sciage sur deux barres chromées et trempées; écoulement de la tête de sciage motorisé avec vitesse réglable; plongée motorisée; inclinaison manuelle de la tête de sciage pour coupes à 45°; jambes à angle. **ACCESSORI:** Pompe; Laser marque coupe à batterie; Rallonge à rouleaux; Butée latérale; Équerre ronde; Jeu de clés de service. **OPZIONALE:** Disque de coupe; Équerre longue; Rallonges additionnels; Meules; Équerre mécanique.

ARTICOLO ITEM ARTICLE	MOD	 mm	 RPM	 kW - Volt	 mm	 mm	 mm	 cm (L-B-H)	 Kg	PREZZO PRICE PRIX €
120284	MANTA INOX 120 LX SA PLUS	450 - 30	2800	4 - 400	1200	180	150	195x90x112	220	6.600,00
120285	MANTA INOX 120 LX SA PLUS	450 - 40	1400	4 - 400	1200	180	150	195x90x112	220	6.800,00
120274	MANTA INOX 150 LX SA PLUS	450 - 30	2800	4 - 400	1500	180	150	225x90x112	240	6.900,00
120275	MANTA INOX 150 LX SA PLUS	450 - 40	1400	4 - 400	1500	180	150	225x90x112	240	7.000,00
120276	MANTA INOX 200 LX SA PLUS	450 - 30	2800	4 - 400	2000	180	150	275x90x112	255	7.400,00
120277	MANTA INOX 200 LX SA PLUS	450 - 40	1400	4 - 400	2000	180	150	275x90x112	255	7.530,00

IT Motorizzazioni e voltaggi a richiesta del cliente. EN Voltage and Power on Request. FR Voltage et puissance sur demande.



MANTA LX

IT









Robusta, precisa, versatile ed economica. Veramente precisa con scorrimento della testa tramite cuscinetti lineari a ricircolo di sfere su due barre cromate e rettificate. Controllo del taglio tramite trazione a cinghia della testa azionata da un volantino posizionato sul "posto operatore". È dotata di pompa sommersa situata all'interno del basamento per il recupero dell'acqua di raffreddamento per il disco. Moto verticale della testa tramite volantino per una regolazione stabile e veloce. Testa inclinabile per tagli a 45°; Gambe angolari. **ACCESSORI:** Set chiavi di servizio; Battuta laterale; Estensore a rulli. **OPZIONALI:** Squadra diagonale; Ulteriori estensioni del banco; Disco diamantato; Squadra meccanica.

EN

Robust, versatile and inexpensive Saw with an extremely accurate cutting. The head slides on two chromium-plated ground bars by means of linear ball-bearings. The cutting head is controlled by traction belts and it is driven by a handwheel positioned by "the operator's place". The machine is equipped with a submersible pump placed inside the base to collect the water cooling the blade. Vertical head motion by means of a handwheel for a fast and stable adjustment. Tilting head for 45° cuts; Angle legs. **ACCESSORIES:** 1 submersible pump; 1 side stop; 1 roller side table; servicing wrenches. **OPTIONALS:** diamond cutting blade; square; additional side tables; laser pointer; mechanic square.

FR

Débiteuse solide, polyvalente et économique. Elle est très précise avec coulissement de la tête sur deux barres chromées et rectifiées par des roulements linéaires. Le coupage est contrôlé par l'entraînement à courroie; la tête est actionnée par un volant positionné sur "le poste de l'opérateur". Elle est équipée d'une pompe submergée placée dans sa base pour collecter l'eau de refroidissement du disque. Mouvement vertical de la tête réglé et stabilisé au moyen d'un volant. Tête de coupage qui peut être inclinée quand on doit exécuter des coupes à 45°; Jambes à angle. **ACCESSOIRES:** 1 pompe; 1 butée latérale; 1 rallonge à rouleaux; Jeu de clés de service. **EN OPTION:** Disque diamant; équerre; Rallonges à rouleaux additionnels; équerre mécanique.

ARTICOLO ITEM ARTICLE	MOD	 mm	 RPM	 kW - Volt	 mm	 mm	 mm	 mm	 cm (L-B-H)	 Kg	PREZZO PRICE PRIX €
130150	MANTA 120 LX CE	350 - 25,4	2800	2,2 - 230	1200	180	110	195x66x87	190	3.600,00	
130151	MANTA 120 LX CE	450 - 30	2800	4 - 400	1200	180	150	195x66x87	195	3.740,00	
130152	MANTA 120 LX CE	450 - 40	1400	4 - 400	1200	180	150	195x66x87	196	3.890,00	
130153	MANTA 120 LX CE	450 - 30	1400	2,2 - 230	1200	180	150	195x66x87	190	3.800,00	
130250	MANTA 150 LX CE	350 - 25,4	2800	2,2 - 230	1500	180	110	218x66x87	220	3.820,00	
130251	MANTA 150 LX CE	450 - 30	2800	4 - 400	1500	180	150	218x66x87	225	4.070,00	
130252	MANTA 150 LX CE	450 - 40	1400	4 - 400	1500	180	150	218x66x87	225	4.210,00	
130258	MANTA 150 LX CE	450 - 30	1400	2,2 - 230	1500	180	150	218x66x87	225	4.010,00	
130300	MANTA 200 LX CE	350 - 25,4	2800	2,2 - 230	2000	180	110	275x66x87	240	4.220,00	
130301	MANTA 200 LX CE	450 - 30	2800	4 - 400	2000	180	150	275x66x87	245	4.420,00	
130302	MANTA 200 LX CE	450 - 40	1400	4 - 400	2000	180	150	275x66x87	246	4.560,00	
130308	MANTA 200 LX CE	450 - 30	1400	2,2 - 230	2000	180	150	275x66x87	238	4.530,00	



MANTA LX SA

IT

Robusta, precisa, versatile ed economica. Veramente precisa con scorrimento della testa tramite cuscinetti lineari a ricircolo di sfere su due barre cromate e rettificate. Controllo del taglio tramite trazione a cinghia della testa azionata da un motoriduttore controllato elettronicamente. È dotata di pompa sommersa situata all'interno del basamento per il recupero dell'acqua di raffreddamento per il disco. Moto verticale della testa tramite volantino per una regolazione stabile e veloce. Testa inclinabile per tagli a 45°; Gambe angolari. **ACCESSORI:** Set di chiavi di servizio; Battuta laterale; Estensore del banco a rulli. **OPZIONALE:** Squadra diagonale; Ulteriori estensori del banco in lamiera; Disco diamantato; Laser segna-taglio; Squadra meccanica.









EN

Robust, versatile and inexpensive Saw with an extremely accurate cutting. The head slides on two chromium-plated ground bars by means of linear ball-bearings. The cutting head is controlled by traction belts and it is driven by an electronic-controlled gearmotor. The machine is equipped with a submersible pump placed inside the base to collect the water cooling the blade. Vertical head motion by means of a handwheel for a fast and stable adjustment. Tilting head for 45° cuts; Angle legs. **ACCESSORI:** Set of servicing wrenches; Side stop; Roller side table. **OPZIONALE:** Diagonal square; Additional side tables; Diamond cutting blade; Laser pointer; Mechanic square

FR

Débiteuse solide, polyvalente et économique. Elle est très précise avec coulissement de la tête sur deux barres chromées et rectifiées par des roulements linéaires. Le coupage est contrôlé par l'entraînement à courroie; la tête est actionnée par un motoréducteur contrôlé électroniquement. Elle est équipée d'une pompe submergée placée dans sa base pour collecter l'eau de refroidissement du disque. Mouvement vertical de la tête réglé et stabilisé au moyen d'un volant. Tête de coupage qui peut être inclinée quand on doit exécuter des coupes à 45°; Jambes à angle. **ACCESSORI:** Jeu de clés de service; Butée latérale; Rallonge à rouleaux. **OPZIONALE:** Équerre diagonale; Rallonges à rouleaux additionnels; Disque diamant; Laser marque coupe; Équerre mécanique.



ARTICOLO ITEM ARTICLE	MOD	 mm	 RPM	 kW - Volt	 mm	 mm	 mm	 cm (L-B-H)	 Kg	PREZZO PRICE €
140150	MANTA 120 LX SA CE	350 - 25,4	2800	2,2 - 230	1200	180	110	195x66x87	210	5.600,00
140151	MANTA 120 LX SA CE	450 - 30	2800	4 - 400	1200	180	150	195x66x87	215	5.650,00
140152	MANTA 120 LX SA CE	450 - 40	1400	4 - 400	1200	180	150	195x66x87	216	5.780,00
140160	MANTA 120 LX SA CE	450 - 30	1400	2,2 - 230	1200	180	150	195x66x87	215	5.770,00
140200	MANTA 150 LX SA CE	350 - 25,4	2800	2,2 - 230	1500	180	110	225x66x87	240	5.600,00
140201	MANTA 150 LX SA CE	450 - 30	2800	4 - 400	1500	180	150	225x66x87	245	5.900,00
140202	MANTA 150 LX SA CE	450 - 40	1400	4 - 400	1500	180	150	225x66x87	246	5.980,00
140209	MANTA 150 LX SA CE	450 - 30	1400	2,2 - 230	1500	180	150	225x66x87	245	5.900,00
140250	MANTA 200 LX SA CE	350 - 25,4	2800	2,2 - 230	2000	180	110	275x66x87	245	5.800,00
140251	MANTA 200 LX SA CE	450 - 30	2800	4 - 400	2000	180	150	275x66x87	265	6.100,00
140252	MANTA 200 LX SA CE	450 - 40	1400	4 - 400	2000	180	150	275x66x87	266	6.220,00
140253	MANTA 200 LX SA CE	450 - 30	1400	2,2 - 230	2000	180	150	275x66x87	265	6.180,00



MANTA Ø 550

IT









Robusta ed economica. Veramente precisa con scorrimento della testa tramite cuscinetti lineari a ricircolo di sfere su due barre cromate e rettificate. È dotata di pompa sommersa situata all'interno del basamento per il recupero dell'acqua di raffreddamento del disco. Moto verticale della testa tramite volantino per una regolazione stabile e veloce. Testa inclinabile per tagli a 45°. **ACCESSORI:** Battuta; Set di chiavi di servizio. **OPZIONALI:** Disco diamantato; Squadra diagonale; Battuta laterale; Estensore piano; Estensore a rulli

EN

Rugged and inexpensive machine with an extremely accurate cutting. The head slides on two chromium-plated ground bars by means of linear ball-bearings. It is equipped with a submersible pump placed inside the base to collect the water cooling the blade. Vertical head motion by means of a handwheel for a fast and stable adjustment. Tilting head for 45° cuts. **ACCESSORIES:** Stop; Set of servicing wrenches. **OPTIONALS:** Diamond cutting blade; Diagonal Square; Side stop; Side table; Roller side table.

FR

Base et table en fer; coulissement de la tête de sciage sur deux barres en acier chromées et rectifiées. Elle est équipée d'une pompe submergée placée dans sa base pour collecter l'eau de refroidissement du disque. Avancement de la tête de sciage au moyen d'une poignée; plongée manuelle au moyen d'un volant à manivelle; inclinaison de la tête de sciage pour coupes à 45°. **ACCESSOIRES:** Butée; Jeu de clés de service. **EN OPTION:** Disque diamant; Équerre diagonale; Butée latérale; Rallonge.

ARTICOLO ITEM ARTICLE	MOD	 mm	 RPM	 kW - Volt	 mm	 mm	 mm	 cm (L-B-H)	 Kg	PREZZO PRICE PRX €
120204ED	MANTA 85-550 monofase	550 - 30	1400	2,2 - 230	720	210	200	127x66x85	112	2.620,00
120205ED	MANTA 85-550 trifase	550 - 30	1400	4 - 400	695	210	200	127x66x85	115	2.620,00
120156ED	MANTA 100-550 monofase	550 - 30	1400	2,2 - 230	920	210	200	140x66x85	125	2.730,00
120157ED	MANTA 100-550 trifase	550 - 30	1400	4 - 400	895	210	200	140x66x85	128	2.730,00
120306ED	MANTA 120-550 monofase	550 - 30	1400	2,2 - 230	1095	210	200	160x66x85	163	2.790,00
120307ED	MANTA 120-550 trifase	550 - 30	1400	4 - 400	1095	210	200	160x66x85	166	2.790,00



MANTA TB BASIC

IT









Robusta ed economica. Veramente precisa con scorrimento della testa tramite cuscinetti lineari a ricircolo di sfere su due barre cromate e rettificate. È dotata di pompa sommersa situata all'interno del basamento per il recupero dell'acqua di raffreddamento per il disco. Moto verticale della testa tramite volantino per una regolazione stabile e veloce. Testa inclinabile per tagli a 45°; Gambe angolari. **ACCESSORI:** 1 schermo protettivo; Set chiavi di servizio. **OPZIONALI:** Disco diamantato; Squadra diagonale; Battuta laterale; Estensore piano; Estensore a rulli; Kit ruote e maniglie di trasporto; motore autofrenante.

EN

Rugged and inexpensive Saw with an extremely accurate cutting. The head slides on two chromium-plated ground bars by means of linear ball-bearings. It is equipped with a submersible pump placed inside its own self circulating water tank to collect the water cooling the blade. Head rise/fall manually operated by means of a handwheel for a fast and stable adjustment. Tilting head for 45 degree angle cut; Angle legs. **ACCESSORIES:** protective screen; servicing wrenches. **OPTIONALS:** diamond cutting blade; side stop; square; transport handles and wheels; self-braking motor.

FR

Base et table en fer; coulissement de la tête de sciage sur deux barres en acier chromées et rectifiées. Elle est équipée d'une pompe submergée placée dans sa base pour collecter l'eau de refroidissement du disque. Déplacement de la tête de sciage au moyen d'une poignée; plongée manuelle au moyen d'un volant à manivelle; inclinaison de la tête de sciage pour coupes à 45°; jambes à angle. **ACCESSOIRES:** 1 écran de protection; Clefs de service. **EN OPTION:** Disque diamant; Butée latérale; équerre; Roues et poignées de transport; Moteur freiné.

ARTICOLO ITEM ARTICLE	MOD	 mm	 RPM	 kW - Volt	 mm	 mm	 mm	 cm (L-B-H)	 Kg	PREZZO PRICE PRX €
130209ED	MANTA TB 85-650 BASIC monofase	650 - 30	1400	2,2 - 230	450	260	250	152x80x87	145	3.100,00
130210ED	MANTA TB 85-650 BASIC trifase	650 - 30	1400	4 - 400	450	260	250	152x80x87	145	3.160,00
130211ED	MANTA TB 100-750 BASIC monofase	750 - 40	900	2,6 - 230	550	330	300	175x80x93	165	3.960,00
130212ED	MANTA TB 100-750 BASIC trifase	750 - 40	1400	4 - 400	550	330	300	175x80x93	165	3.250,00
130205ED	MANTA TB 120-800 BASIC trifase	800 - 40	1400	4 - 400	700	330	325	195x80x93	185	3.380,00











MANTA LX TB

IT
Robusta, precisa, versatile ed economica. Costruita principalmente per il taglio di blocchi atti alla costruzione d'immobili. Veramente precisa con scorrimento della testa tramite cuscinetti lineari a ricircolo di sfere su due barre cromate e rettificata. Controllo del taglio tramite trazione a cinghia della testa azionata da un volantino posizionato sul "posto operatore". È dotata di pompa sommersa situata all'interno del basamento per il recupero dell'acqua di raffreddamento per il disco. Moto verticale della testa tramite volantino per una regolazione stabile e veloce. Testa inclinabile per tagli a 45°; Avanzamento disponibile anche motorizzato; Gambe angolari. **ACCESSORI:** Schermo protettivo; Set di chiavi di servizio. **OPZIONALI:** Disco diamantato; Squadra diagonale; Estensore del banco in lamiera; Estensore del banco a rulli.

EN
Heavy-duty, versatile and inexpensive machine with an extremely accurate cutting. Mainly suitable to cut masonry blocks. The head slides on two chromium-plated ground bars by means of linear ball-bearings. The cutting head is controlled by traction belts driven by a handwheel positioned by "the operator's place". The machine is equipped with a submersible pump placed inside the base to collect the water cooling the blade. Vertical head motion by means of a handwheel for a fast and stable adjustment. Tilting head for 45° cuts; Automatic version is also available; Angle legs. **ACCESSORIES:** Protective screen; Set of servicing wrenches. **OPTIONALS:** Diamond cutting blade; Diagonal square; Side table; Roller side table.

FR
Robuste, précise, polyvalente et économique. Principalement construit pour couper des blocs pour la construction de bâtiments, coulissement de la tête de sciage sur deux barres en acier chromées et rectifiées. Commande de coupe par entraînement par courroie de la tête entraînée par un volant positionné sur le "poste de conduite". Elle est équipée d'une pompe submergée placée dans sa base pour collecter l'eau de refroidissement du disque. Avancement et plongée de la tête de sciage au moyen d'un volant à manivelle (version automatique disponible); inclinaison de la tête de sciage pour coupes à 45°; jambes à angle. **ACCESSOIRES:** écran de protection; Jeu de clés de service. **EN OPTION:** Disque diamant; Équerre diagonale; Rallonge.

ARTICOLO ITEM ARTICLE	MOD	 mm	 RPM	 kW - Volt	 mm	 mm	 mm	 cm (L-B-H)	 Kg	PREZZO PRICE PRIX €
130204ED	MANTA LX TB 120-750 MONOFASE	750 - 40	900	2,6-230	700	330	300	195x80x90	190	4.840,00
130200ED	MANTA LX TB 120-750 TRIFASE	750 - 40	1400	4-400	700	330	320	195x80x90	190	4.130,00
130203ED	MANTA LX TB 120-800 TRIFASE	800 - 40	1400	5,5-400	600	360	325	195x80x90	200	4.720,00
130202ED*	MANTA LX TB 120-1000 TRIFASE	1000 - 60	900	7,5-400	550	450	400	195x80x103	270	5.960,00
140159	MANTA LX TB SA 120-800 TRIFASE	800 - 40	1400	5,5-400	600	360	325	195x80x90	200	6.200,00
140162*	MANTA LX TB SA 120-1000 TRIFASE	1000 - 60	900	7,5-400	550	450	400	195x80x103	270	7.300,00

*IT Testa non inclinabile per tagli a 45 gradi. *EN No tilting head for 45° cuts. *FR La tête n'est pas inclinable pour coupes à 45°.











MANTA TB 150 SPECIAL

IT
Struttura e banco di lavoro in ferro; gambe smontabili angolari; avanzamento della testata disponibile sia manuale sia motorizzato. Sollevamento testata motorizzata tramite motoriduttore (sia per la versione manuale sia per l'automatica). Testata non inclinabile. Motore autofrenante. **ACCESSORI:** Schermi protettivi su ambo i lati; Pompa; Fermablocchi fronte lama; Set di chiavi di servizio; Software per tagli incrementali (solo per versione automatica). **OPZIONALI:** Disco di taglio; Estensore a rulli; Mensole laterali.

EN
Frame and bench in steel; detachable angled legs; head travel manually or automatically operated. Head rise/fall motorized by means of a gearbox (both models manual / automatic). No tilting head. Self-braking motor. **ACCESSORIES:** Protection side screens; Pump; Stop in front of the blade; Set of servicing wrenches; Software for incremental cuts (only for automatic version). **OPTIONALS:** Cutting blade; Side roller table; Side brackets

FR
Châssis et table en fer; jambes démontables à angle; déplacement de la tête de sciage disponible soit manuelle soit automatique. Plongée de la tête motorisée au moyen d'un motoréducteur (soit pour le modèle manuel soit automatique). La tête n'est pas inclinable. Moteur freiné. **ACCESSOIRES:** Écrans de protection sur les deux côtés; Pompe; Système de blocage du matériel placé devant la lame; Jeu de clés de service; Software d'incrémentation de passe (dans la version automatique). **EN OPTION:** Disque de coupe; Rallonge à rouleaux; Supports latéraux.

ARTICOLO ITEM ARTICLE	MOD	 mm	 RPM	 kW - Volt	 mm	 mm	 mm	 cm (L-B-H)	 Kg	PREZZO PRICE PRIX €
150004	TB 150 SPECIAL - 1000*	1000	900	7,5 - 400	1500	550	400	320x108x167	506	11.800,00
150006	TB 150 SPECIAL - 1000 AUTO*	1000	900	7,5 - 400	1500	550	400	320x108x177	546	17.400,00
150008	TB 150 SPECIAL - 1200*	1200	900	11 - 400	1450	550	490	320x108x167	516	14.850,00
150010	TB 150 SPECIAL - 1200 AUTO*	1200	900	11 - 400	1450	550	490	320x108x177	556	19.360,00

*IT Inverter variatore velocità lama. *EN Inverter for blade variable speed. *FR Inverter avec variateur de vitesse du disque.

I prezzi verranno comunicati al momento dell'ordine.



TAGLIERINE MASONRY / PORTABLE SA DÉBITEUSES / SCIES								PREZZO PRICE PRIX €	PREZZO PRICE PRIX €	PREZZO PRICE PRIX €
MANTA	ED 50	ED 50-400	ED 50-450							
MANTA	ED 50-600									
MINI	60	90	OS							
MANTA	TP 650	750	800	1000						
MANTA	65	ED	AL		EV					
MANTA	85	ED	AL	INOX	EV	MANTA Ø550	TB BASIC			
MANTA	100	ED	AL	INOX	EV	MANTA Ø550	TB BASIC			
MANTA	120	ED	AL	INOX	EV	MANTA Ø550	TB BASIC			
MANTA	120	LX	LX SA	LX TB	ED SPECIAL	INOX LX				
MANTA	150	ED	AL	INOX						
MANTA	150	LX	LX SA	INOX LX	ED SPECIAL	INOX LX	INOX LX SA PLUS			
MANTA	200	ED	AL	INOX						
MANTA	200	LX	LX SA	INOX LX	ED SPECIAL	INOX LX	INOX LX SA PLUS			
MANTA	TB 150 SPECIAL	1000	1200							



LEVIGATRICI POLISHING MACHINES POLISSEUSES				PREZZO PRICE PRIX €	PREZZO PRICE PRIX €	PREZZO PRICE PRIX €
CICALA						
PANDA	LUPESSA	TIGRE				
KOALA						
GAZZELLA	GAZZELLA 2T					
MULTISPEED						
PANTERA	PANTERA SE	2T				
GIRAFFA						
COLONNA GIRAFFA						



FRESE SAW DÉBITEUSES							PREZZO PRICE PRIX €	PREZZO PRICE PRIX €	PREZZO PRICE PRIX €
SCORPIONE									
MANTA 200	ECO M	ECO SA	COMPACT						
MANTA 250	ECO M	ECO SA	COMPACT	LX prisma	AUTOMATIC	SPECIAL			
MANTA 300	ECO M	ECO SA	COMPACT	LX prisma	AUTOMATIC	SPECIAL			
MANTA	POKER	JR							

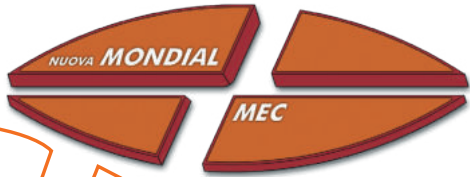

Accessori Taglierine



Accessories for Cutting Machines



Accessoires pour Tronçonneuses et Débriteuses



BATTUTA LATERALE

IT
Battuta laterale

EN
Side Stop

FR
Butée latérale

ARTICOLO ITEM ARTICLE	UTILIZZABILE SU AVAILABLE ON DISPONIBILE SUR	LUNGHEZZA LENGHT LONGUEUR mm	PREZZO PRICE PRIX €
17M002	MANTA 65 - 85 - 100	690	51,00
17M003	MANTA 120 - 150 - 200 ECO - COMPACT	1200	87,00
17M009	SPECIAL - AUT	1500	130,00

**IT La battuta viene fornita completa di leve. *EN The side stop is supplied complete with levers
FR La butée latérale est livrée complète avec des leviers.

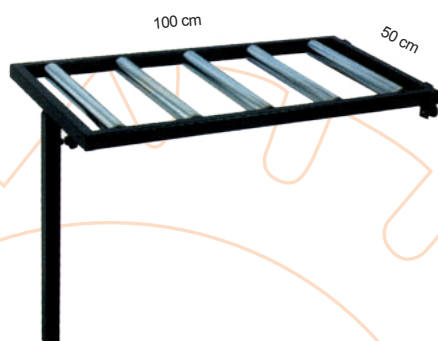

ESTENSORE A RULLI

IT
Estensore a rulli

EN
Side roller table

FR
Rallonge à rouleaux.

ARTICOLO ITEM ARTICLE	UTILIZZABILE SU AVAILABLE ON DISPONIBILE SUR	PESO WEIGHT POIDS Kg	PREZZO PRICE PRIX €
17M000	TUTTI I MODELLI ALL MODELS TOUS LES MODELES	13	340,00



ESTENSORE PIANO

IT
Estensore piano

EN
Flat extension table

FR
Rallonge plan

ARTICOLO ITEM ARTICLE	UTILIZZABILE SU AVAILABLE ON DISPONIBILE SUR	PESO WEIGHT POIDS Kg	PREZZO PRICE PRIX €
17M001	TUTTI I MODELLI ALL MODELS TOUS LES MODELES	7	148,00
04NS000T00	MINI MANTA Estensore senza piede / Side table without leg Rallonge sans pied	4	70,00
17M020	TUTTI I MODELLI - ALL MODELS TOUS LES MODELES Estensore senza piede / Side table without leg Rallonge sans pied - 45 cm x 30 cm	6	80,00



KIT RUOTE MOBILE (COPPIA)

IT
Kit ruote mobile (coppia)

EN
Pair of Moving Wheels

FR
Jeu de roues mobiles

ARTICOLO ITEM ARTICLE	UTILIZZABILE SU AVAILABLE ON DISPONIBILE SUR	PEZZI PIECES	PREZZO PRICE PRIX €
17M006	-	2 ruote 2 wheels 2 roues	94,00
18M008	TB BASIC	2 ruote e maniglie 2 wheels and handles 2 roues et poignées	230,00

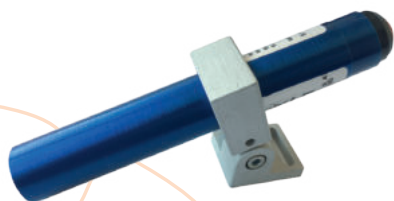

LASER A BATTERIA

IT
Laser

EN
Battery powered line laser

FR
Laser de guidage

ARTICOLO ITEM ARTICLE	mW	BATT	PREZZO PRICE PRIX €
021063	1	solo STILO	240,00
18F035	1	STAFFA LASER	45,00

**IT con staffa. *EN with holder. *FR avec support.*



MANICOTTO A SFERA

IT
Manicotto a sfera

EN
Ball bearing with dust cover

FR
Roulement avec anneau de protection des poussières

ARTICOLO ITEM ARTICLE	DIAM. mm	PREZZO PRICE PRIX €
030120	Ø 25	25,00
030098	Ø 30	31,00
030106	Ø 40	38,00
030097	Ø 50	45,00



POMPA IMMERSIONE

IT
Pompa immersione. Disponibili altre tensioni.

EN
Pump. Other voltages available.

FR
Pompe. Autres voltages disponibles

ARTICOLO ITEM ARTICLE	PORTATA LH FLOW RATE CAPACITE	POTENZA POWER PUISSANCE	HZ	PREZZO PRICE PRIX €
020022NMM	LT/H 1000-1200	V 220/240	50 / 60	69,00
020076NMM*	LT/H 1500-1800	V 220/240	50 / 60	80,00
020083NMM*	LT/H 1000-1200	V 220/240	50 / 60	74,00
020084NMM*	LT/H 700-750	V 110/115	50 / 60	74,00
020492	LT/H 6000	V 220/230	50 / 60	208,00

**IT Cavo 4 mt. *EN 4 ms. cable. *FR Cable 4 mt.*



SQUADRA DIAGONALE EDILIZIA

IT
Squadra diagonale edilizia

EN
Diagonal Square

FR
équerre diagonale

ARTICOLO ITEM ARTICLE	UTILIZZABILE SU AVAILABLE ON DISPONIBLE SUR	PREZZO PRICE PRIX €
17M005	TUTTI I MODELLI ALL MODELS TOUS LES MODELES	112,00
17M033	ED 50-600-700	120,00

GIRAFFA



IT

La macchina Mod. GIRAFFA è una levigatrice robusta e versatile a ponte mobile su vasca in lamiera. Il braccio con snodi su più assi permette il passaggio, tra piano di lavoro e piatto di attacco degli abrasivi di 300mm. Il comando si sollevamento asse di lavoro del braccio ha una corsa totale di 150mm. Il collegamento, asse albero di rotazione con piatto porta abrasivi, è costituito da un sistema a giunto omocinetico; questo permette di lavorare con il piatto sempre perfettamente orizzontale al piano di appoggio e di attenuare al massimo le vibrazioni trasmesse.

ACCESSORI: Disco porta abrasivi Frankfurt; Anello protezione abrasivi; Spatola gommata; Set di chiavi di servizio.

OPZIONALI: Pompa.

EN

Rugged and versatile arm polishing machine working over a water tray in steel sheet. The clearance between the bed and the honing plate is 300 mm. Thanks to the arm with joints on multiple axes. The maximum lifting stroke is 150 mm. A constant-velocity joint connecting the stone holding plate to the shaft axis of the swivelling arm allows a constant horizontal work and reduce the vibrations transmitted.

ACCESSORIES: Stone holding plate Frankfurt; Splash guard; Spatula in rubber; Set of servicing wrenches.







OPTIONALS: Pump

FR

Polisseuse robuste et versatile à pont mobile sur bac en tôle d'acier. Le bras avec jonctions sur plusieurs axes permet un passage de 300 mm entre le plan de travail et le plateau d'attelage abrasifs. La course de levage maximum du bras est de 150 mm. La jonction entre l'axe de l'arbre tournant et le plateau d'attelage abrasifs se fait au moyen d'un système à joint homocinétique. Cela permet de travailler avec le plateau toujours parfaitement horizontal au plan d'appui et d'atténuer les vibrations transmises.

ACCESSOIRES: Plateau d'attelage abrasifs Frankfurt; Garde boues; Spatule en caoutchouc; Jeu de clés de service.







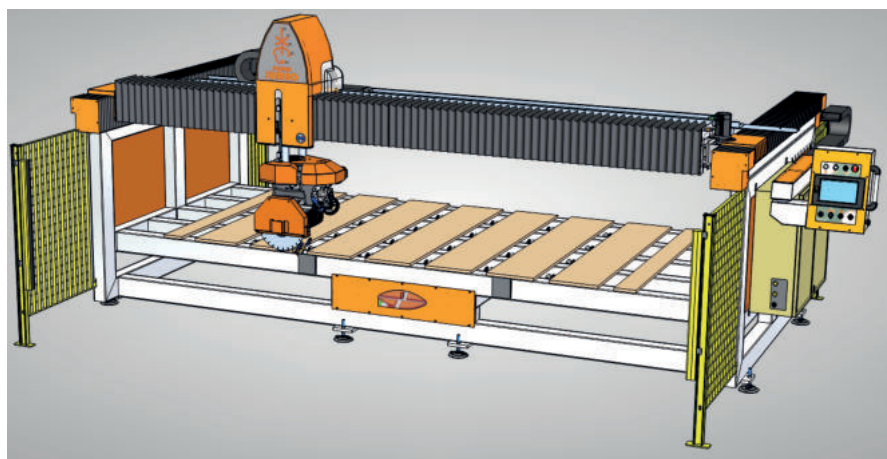
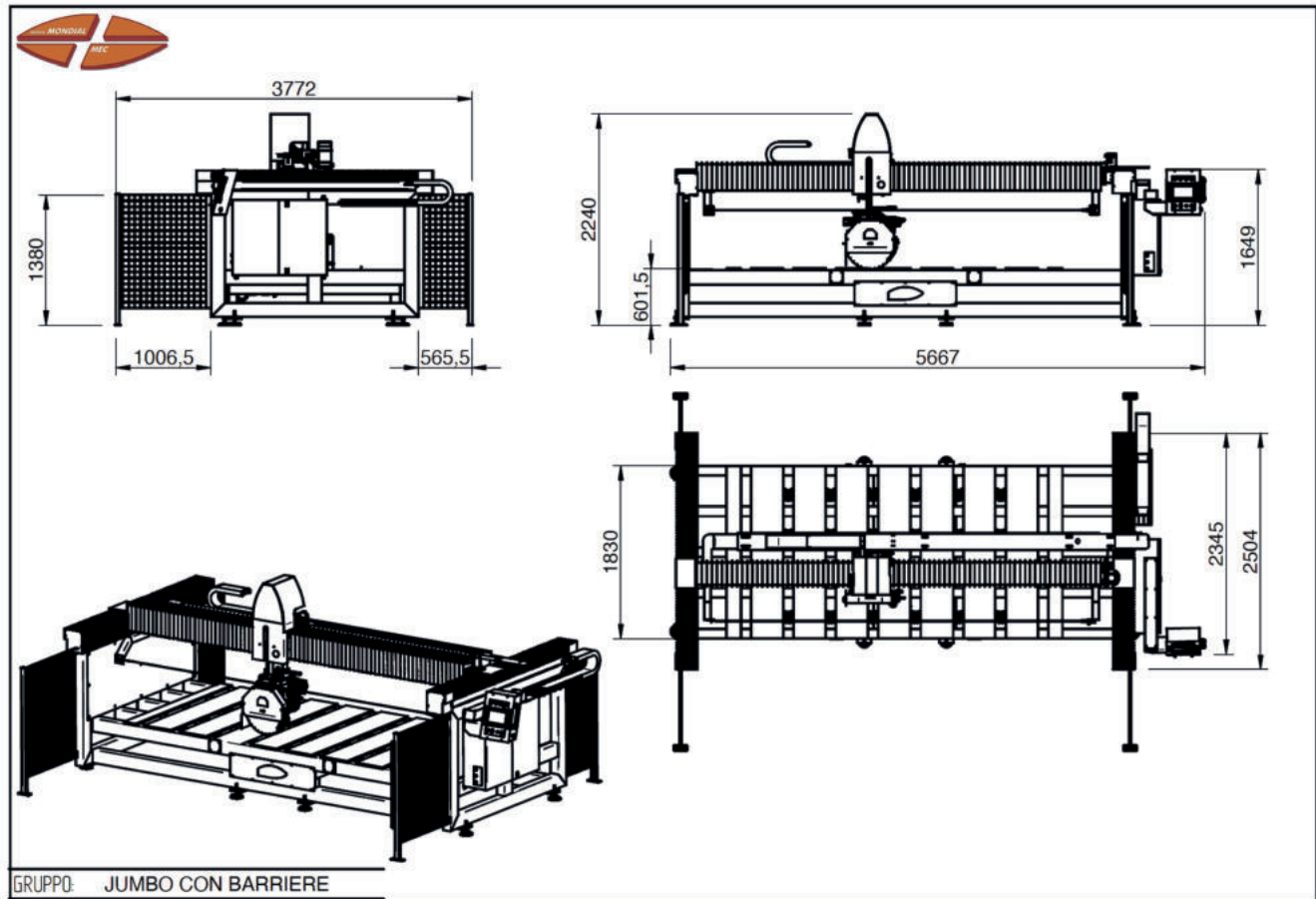

EN OPTION: Pompe.

ARTICOLO ITEM ARTICLE	MOD.	 mm	 kW - Volt	 275 CA	 cm (L-B-H)	 cm	 cm	 Kg	PREZZO PRICE PRIX €
111000	MANETTONE GIRAFFA - Man. Trifase con vasca	300	4 - 400	275 CA	168x118x150	140x114*	150	230	6.700,00
111003	MANETTONE GIRAFFA - Man. Monofase con vasca	300	2,2 - 230	275 CA	168x118x150	140x114*	150	215	6.700,00

IT Voltaggio e potenza a richiesta. *EN* Voltage and power on request. *FR* Voltage et puissance sur demande.
**IT* Misure superficie lavorabile max. **EN* Maximum workable dimensions. **FR* Dimension max usinable.

MANTA POKER JUMBO BRUSHLESS 4+1



ARTICOLO ITEM ARTICLE	MOD	 mm	 RPM	 kW - Volt	 mm	 mm	 mm	 cm (L-B-H)	 Kg	PREZZO PRICE PRIX €
150769	FRESA MANTA POKER JUMBO BRUSHLESS 4+1	400 - 40	2800	8 - 400	3500	400	120	546x220x217	2200	43.200,00

MANTA POKER JUMBO BRUSHLESS 4+1

FUNZIONI DI SERIE/ Standard features / équipement de série

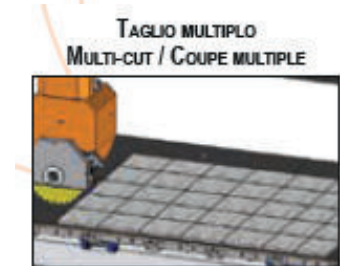
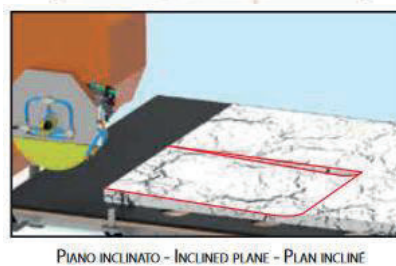
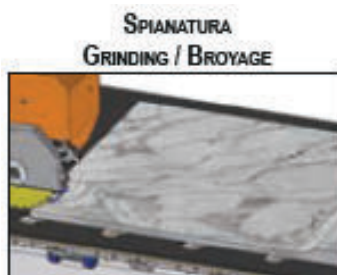
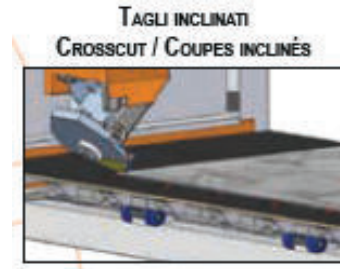

FUNZIONE OPZIONALE
Optional features
équipement en option



DESCRIZIONE

Fresa robusta e compatta per realizzare tagli trasversali, longitudinali e diagonali (4 assi motorizzati). Il movimento della testa di taglio è gestito tramite CNC touch screen integrato nel quadro pensile a bordo macchina, con interfaccia 10 pollici semplice ed intuitiva. Le principali caratteristiche tecniche sono: Corsa Asse X : 3500 mm.; Corsa Asse Y: 1850 mm. Soffietti di protezione assi in speciale tela resistenti all'abrasione. Struttura verniciata con trattamento di ceramicatura. Velocità di movimento della testa di taglio gestita tramite drive e motori brushless; Rotazione motorizzata asse C da 0° a 180° ed inclinazione della testa manuale con visualizzazione dei gradi su display. Motore disco dotato di attacco M14 destro per foretti e frese. Funzioni di serie: taglio singolo, taglio diagonale, taglio inclinato dell'asse A interpolato con X o Y, tagli multipli su asse X e Y, spianatura con disco e possibilità di realizzare un piano inclinato. Conforme alle normative CE. Barriere o altre protezioni sono in appannaggio delle rispettive normative degli stati.

ACCESSORI:

Banco in legno marino dotato di sistema integrato di sollevamento lastre, CNC pensile con interfaccia touch screen, piedi regolabili, laser segna taglio di colore verde.

OPZIONALI:

Disco diamantato, Inverter lama per la regolazione della velocità di rotazione del disco, Vasca amovibile in PVC per la raccolta dell'acqua di raffreddamento del disco, Barriere optoelettriche o riparo frontale, Comando remoto, Vasca di raccolta con pompa sommersa per il recupero e ricircolo dell'acqua di raffreddamento del disco, Posizionamento, installazione e training operatori.

MANTA POKER JUMBO AUTOMATIC BRUSHLESS

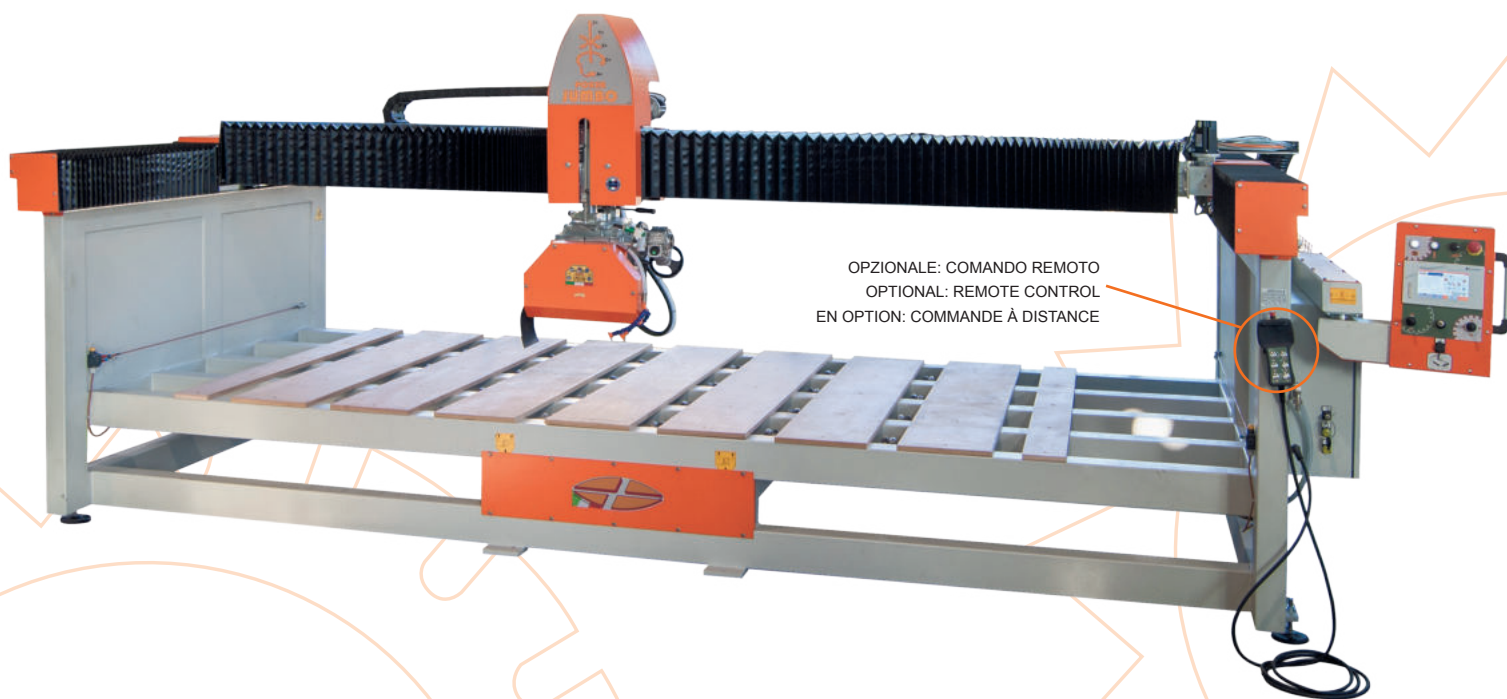

PANNELLO OPERATORE - OPERATOR PANEL



ASSE A - AXIS A



ASSE C - AXIS C



OPZIONALE

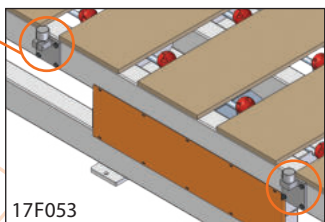

17F053

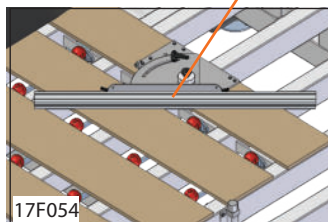

17F054

OPZIONALE

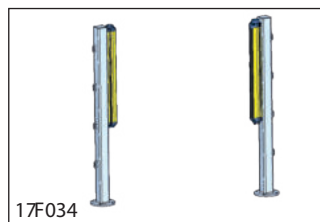

17F034

OPZIONALI / Optional / en option

ARTICOLO ITEM ARTICLE	DESCRIZIONE DESCRIPTION / DESCRIPTION	PREZZO PRICE / PRIX €
17F053	Battute frontali per lastra / Frontal Stops for slabs / Barres frontales pour dalle	550,00
17F054	Battuta per tagli diagonali / Stop for diagonal cuts / Barre pour coupes diagonales	860,00
17F034	Kit barriera frontali fotocellula Poker / Poker front photocell barrier set Kit de barrières photoélectriques avant pour la Poker	2.260,00
SW 500.000	Macro Capitelli	1.200,00

*IT ulteriori accessori nella sezione dedicata Accessori frese. EN additional accessories in the section Accessories for saws
FR accessoires supplémentaires dans la section Accessoires pour Débêteuses*

IT
Fresa robusta e compatta per tagli sull'asse X (longitudinale) e Y (trasversale). Il movimento della testa di taglio è gestito tramite CNC touch screen integrato nel quadro pensile a bordo macchina, con interfaccia semplice ed intuitiva. Le principali caratteristiche tecniche sono: Corsa Asse X : 3500 mm.; Corsa Asse Y: 1830 mm. Asse Z: 270mm.; Velocità movimento della testa di taglio gestita tramite drive e motori brushless; Rotazione manuale asse C a tre posizioni fisse 0°, 90°, 180° ed inclinazione della testa manuale con visualizzazione dei gradi su display. Funzioni di serie: taglio singolo, taglio inclinato dell'asse A interpolato con X o Y, tagli multipli su asse X e Y, spianatura con disco e possibilità di realizzare un piano inclinato. Conforme alle normative CE. Barriere o altre protezioni sono in appannaggio delle rispettive normative degli stati.

ACCESSORI: Banco in legno marino dotato di sistema integrato di sollevamento lastre; CNC pensile con interfaccia touch screen; piedi regolabili; dispositivo ottico segnataglio a luce verde.

OPZIONALE: Disco diamantato; inverter per la regolazione della velocità di rotazione del disco; funzione profili; comandi assi remoto per il controllo a distanza; Vasca di raccolta con pompa sommersa per il recupero e ricircolo dell'acqua raffreddamento del disco; Posizionamento, installazione e training operatori.

EN
Robust and solid machine. It cuts both length ways (X axis) and cross ways (Y axis). The head traverse is driven by means of the CNC touch screen integrated in the hanging panel on board of the machine with simple and intuitive interface. The main features are: X Axis Traverse: 3500 mm; Y Axis Traverse: 1830 mm. Z Axis Raise: 270 mm. Cutting head speed driven by drive and brushless motors. Manual C Axis rotation at 3 fixed positions: 0, 90, 180 degree and head manual inclination with display to visualize the degrees. Standard features: single cut; A Axis crosscut interpolated with X or Y Axis; multi-cut on X and Y Axis; grinding with blade and possibility to realize an inclined plane. Complying with CE standards. Barriers or other protections are prerogative of the respective state regulations.









ACCESSORIES: Marine wood bench with integrated system to lift slabs; hanging CNC with touch screen interface; adjustable feet; optical cut marker device at green light.

OPTIONALS: Diamond blade; inverter for blade rotation speed adjustment; profile function; remote keyboard; tray with submersible pump to collect and recover the water cooling the blade; positioning, installation and training of operators.

FR
Débêteuse solide et compacte de coupage sur les axes X (longitudinal) et Y (transversal). La course de la tête de coupe est géré au moyen d'un CNC touch screen intégré dans le tableau suspendu au bord de la machine avec interface simple et intuitive. Les caractéristiques principales sont: Course Axe X: 3500mm; Course Axe Y: 1830 mm; Levée Axe Z: 270 mm; Vitesse de la tête de coupe gérée par drive et moteurs brushless. Rotation manuelle de l'Axe C à 3 positions fixes: 0-90-180 degrés et inclinaison de la tête manuelle avec visualisations des degrés sur display. Equipement de série: Coupe unique; coupe incliné de l'Axe A interpolé avec X ou Y; coupe multiple sur Axe X et Y; Broyage avec disque et possibilité de réaliser un plan incliné. Conforme aux règlements CE. Les barrières ou autres protections sont prérogatives des respectives réglementations des pays.

ACCESSOIRES: Banc en bois marin avec système de levage de plaque intégré; CNC suspendu avec interface touch screen; pieds de soutien réglables; dispositif optique marque coupe vert.

EN OPTION: Disque diamanté; inverter pour ajuster la vitesse de rotation du disque; fonction de profils; boîtier de commande à distance; bac avec pompe submergée pour la circulation de l'eau de refroidissement du disque; placement, installation et training des opérateurs.

ARTICOLO ITEM ARTICLE	MOD	 mm	 RPM	 kW - Volt	 mm	 mm	 mm	 cm (L-B-H)	 Kg	PREZZO PRICE PRIX €
150765	FRESA MANTA POKER JUMBO AUTO BRUSHLESS	450 - 40	1400	8 - 400	3500	400	150	546x220x217	2100	37.900,00

MANTA POKER JUMBO BASIC



DISPLAY ASSE A - AXIS A



ASSE A - AXIS A



ASSE C - AXIS C



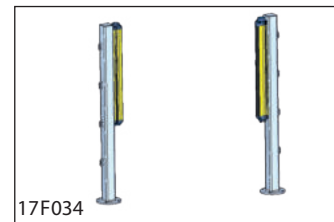
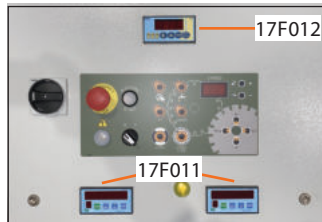
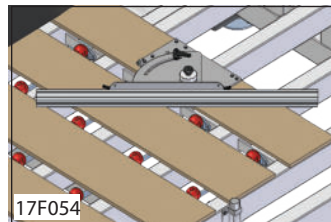
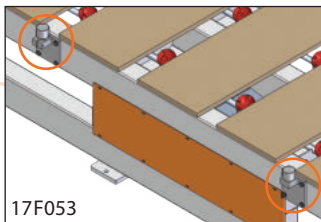

OPZIONALI / Optional / en option

ARTICOLO ITEM ARTICLE	DESCRIZIONE DESCRIPTION / DESCRIPTION	PREZZO PRICE / PRIX €
17F053	Battute frontali per lastra / Frontal Stops for slabs / Barres frontales pour dalle	550,00
17F054	Battuta per tagli diagonali / Stop for diagonal cuts / Barre pour coupes diagonales	860,00
17F080	Encoder per assi X, Y e Z con display / Encoder for X, Y and Z axes with display Encoder axes X/Y/Z avec affichage digitale	2.000,00
17F081	Encoder per assi X e Y con display / Encoder for X and Y axis with display / Encoder axe X/Y avec affichage digitale	1.450,00
17F034	Kit barriere frontali fotocellula Poker+Grigliato / Poker front photocell barrier set Kit de barrières photoélectriques avant pour la Poker	2.200,00

*IT ulteriori accessori nella sezione dedicata Accessori frese. *EN additional accessories in the section Accessoires for saws
FR accessoires supplémentaires dans la section Accessoires pour Débiteuses*

IT
Fresa compatta per tagli sull'asse X (longitudinale) e Y (trasversale). Il movimento della testa di taglio è gestito tramite scheda elettronica. Le principali caratteristiche tecniche sono: Corsa Asse X: 3500 mm.; Corsa Asse Y: 1650 mm.; Velocità movimento della testa di taglio gestita tramite inverter; Rotazione testa manuale 0°-90°; Inclinazione testa manuale 0°- 90° tramite volantino. Conforme alle normative CE. Barriere o altre protezioni sono in appannaggio delle rispettive normative degli Stati.

ACCESSORI: Banco in legno marino; Leggio comandi per la gestione movimenti della testa e di display di controllo velocità; Programma per taglio a passate; Piedi regolabili.

OPZIONALI: Disco diamantato; Battute frontali; Battute per tagli diagonali; encoder con display; Laser segnataglio; Vasca provvista di pompa sommersa per il recupero e ricircolo dell'acqua di raffreddamento del disco; Posizionamento, installazione e Training operatori.

EN
Robust and versatile monolithic machine. It cuts both length ways (X axis) and cross ways (Y axis). The head traverse is driven by means of an electronic program card. The main technical features are: X Axis Traverse: 3500 mm.; Y Axis Traverse: 1650 mm.; Cutting head speed driven by inverter; manual turning head (0-90 degree); head inclination (0-90 degree) by means of a hand-wheel. CE marking. Barriers or other protections are prerogative of the respective state regulations.









ACCESSORIES: Marine ply wood bench; Control panel for managing head movements and speed control display; Step cutting facility; Adjustable feet.

OPTIONALS: Diamond blade; Frontal stops; Stop for diagonal cuts; Encoder with display; Laser pointer; Tray with pump to collect and recover the disc cooling water; Positioning. Installation of the machine and Training of operators.

FR
Débiteuse pourvue d'une structure solide et compacte. Le coupage sur deux axes est géré par une carte électronique. Les données techniques principales sont: Course Axe X: 3500 mm.; Course Axe Y: 1650 mm.; Vitesse du mouvement de la tête de coupage gérée par un inverter; Rotation manuelle de la tête (0°- 90°); Inclinaison manuelle de la tête 0°/90° au moyen d'un volant. Conforme aux standards CE. Les barrières ou autres protections sont prérogative des respectives réglementations des pays.

ACCESSOIRES: Banc en bois contre-plaqué de haute qualité; Console de gestion des mouvements de la tête avec affichage de contrôle de la vitesse; Fonction de coupes à plusieurs passées; Pieds de soutien réglables.

EN OPTION: Disque diamanté; Barres frontales pour dalle; Barre pour coupes diagonales; Encoder avec affichage digitale; Laser marque coupe; Bac avec pompe submergée pour la circulation de l'eau de refroidissement du disque; Installation et training des opérateurs.

ARTICOLO ITEM ARTICLE	MOD									PREZZO PRICE PRIX €
150757	FRESA MANTA POKER JUMBO BASIC	450 - 40	1400	5,5 - 400	3500	400	140	546x220x217	1500	28.500,00

IT Voltaggio e potenza a richiesta. EN Voltage and power on request. FR Voltage et puissance sur demande.

MANTA 250-300 SPECIAL



1 ESTENSORE INCLUSO
1 SIDE ROLLER INCLUDED
1 RALLONGE INCLU





IT
Segatrice automatica - Semplice e robusta. Adatta sia al piccolo laboratorio che alla grande industria. Banco in legno marino dotato di sistema di sollevamento lastre che permette il posizionamento pluridirezionale del materiale. Possibilità di taglio da 90° a 45° per ogni tipo di materiale lapideo. Movimenti della testa motorizzati (longitudinale-salita/discesa). Gestione del movimento longitudinale della testa tramite sistema elettronico di controllo della velocità regolabile dall'operatore.

ACCESSORI: Vasca estraibile per raccolta acqua; Pompa sommersa per raffreddamento disco; Chiavi di servizio; 1 Estensore a rulli; 2 Supporti laterali fissi; Battuta laterale; Sistema taglio a incremento.

OPZIONALI: Ulteriori estensori; Disco diamantato; Squadra meccanica; Laser segnataglio.

EN
Automatic Stone Slab Saw - Heavy-duty and easy to run. Suitable for both small stone shops and large industrial stone fabrication shops. The marine ply wood cutting bed is equipped with a lifting system for multi-directional positioning of slabs. Omni-Roller wheels making turning the slab allowing an easy job. It is provided with an electric raise and fall, electric traverse and the speed control is adjustable by the operator. The head can be adjusted from 90 to 45 degrees to enable cuts.









ACCESSORIES: Tank collecting water; Submersible Pump to cool the blade; Service wrenches; 1 side roller table; 2 fixed side holders; Side Stop; Incremented cut system.

OPTIONALS: Extra roller tables; Diamond cutting Blade; Mechanic square; Electric laser pointer

FR
Débiteuse automatique - Economique et très simple à l'utilisation. Adapte pour les travaux soit dans les petites marbreries et soit dans les grandes industries. Le banc en bois contre-plaqué de haute qualité, dont elle est équipée, est pourvu d'un système de levage des dalles qui permet de bouger le matériel dans toutes directions. Possibilité de coupage de n'importe quelle pierre avec inclinaison de la tête de 90° à 45°. Les mouvements longitudinal - montée/ descente sont motorisés. Un système électronique de contrôle de vitesse, réglable par l'opérateur, gère le mouvement longitudinal de la tête.

ACCESSOIRES: Bac amovible de collecte eau; Pompe submergée pour le refroidissement du disque; Jeu de clefs de service; 2 supports latéraux fixes; 1 rallonge à rouleaux; Butée latérale; Système d'incrément de passe.

EN OPTION: Rallonges à rouleaux supplémentaires; Disque diamanté; Laser marque-coupe; équerre mécanique.

ARTICOLO ITEM ARTICLE	MOD	 mm	 RPM	 kW - Volt	 mm	 mm	 mm	 cm (L-B-H)	 Kg	PREZZO PRICE PRIX €
150400	FRESA MANTA 250 SPECIAL CE	450 - 40	2800	4 - 400*	2700	200	150	342x102x140	600	14.900,00
150401	FRESA MANTA 250 SPECIAL CE	450 - 40	2800	5,5 - 400*	2700	200	150	342x102x140	600	15.200,00
150402	FRESA MANTA 250 SPECIAL CE	450 - 40	1400	5,5 - 400*	2700	200	150	342x102x140	600	15.680,00
150454	FRESA MANTA 300 SPECIAL CE	450 - 40	2800	5,5 - 400*	3200	200	150	395x102x140	700	16.600,00
150452	FRESA MANTA 300 SPECIAL CE	450 - 40	1400	5,5 - 400*	3200	200	150	395x102x140	700	17.500,00
150461	FRESA MANTA 300 SPECIAL CE -C	450 - 40	400 - 3000	11 - 400* - 1/2GAS	3200	200	150	395x102x140	780	20.800,00
150456	FRESA MANTA 300 SPECIAL CE PLUS	450 - 40	400/2800	5,5 - 400*	3200	200	150	395x102x140	700	18.580,00

*IT Disponibile in versione monofase 2,2 kw.2800/1400 RPM. *EN Single phase is also available - 2.2 kW - 2800/1400 RPM. *FR Disponible monophasé 2.2 kW - 2800/1400 RPM

MANTA 250-300 AUTOMATICA



1 ESTENSORE INCLUSO
1 SIDE ROLLER INCLUDED
1 RALLONGE INCLU

IT
Segatrice automatica - Semplice e robusta. Adatta sia al piccolo laboratorio che alla grande industria. Banco in legno marino. Possibilità di taglio da 90° a 45° per ogni tipo di materiale lapideo. Movimenti della testa motorizzati (longitudinale - salita/discesa). Gestione del movimento longitudinale della testa tramite sistema elettronico di controllo della velocità regolabile dall'operatore.

ACCESSORI: Vasca estraibile per raccolta acqua; Pompa sommersa per raffreddamento del disco; Chiavi di servizio; 1 Estensore a rulli; 2 supporti laterali fissi; Battuta laterale; Sistema taglio a incremento.

OPZIONALI: Ulteriori Estensori; Disco diamantato; PLC per taglio ed incremento; Laser segna taglio; Squadra meccanica.

EN
Automatic Stone Slab Saw - Heavy-duty and easy to run. Provided with a plywood bench. Suitable both for small workshops and big industries processing any kind of stone material. Cuts from 90 to 45°. Motorized head movements (longitudinal - up and down). The head longitudinal movement is driven by an electronic speed control system adjustable by the operator.









ACCESSORIES: Movable Tank collecting water; Submersible Pump to cool the blade; Service wrenches; 1 roller bench extension; 2 fixed side holders; Side Stop; Incremented cut system.

OPTIONALS: Extra roller extensions; Diamond cutting Blade; PLC driving the increment cut; Cut signal Laser; Mechanic square.

FR
Débiteuse automatique - Economique et très simple à l'utilisation. Adapte pour les travaux soit dans les petites marbreries et soit dans les grandes industries. Pourvue de banc en bois contre-plaqué de haute qualité. Possibilité de coupage de n'importe quelle pierre avec inclinaison de la tête de 90° à 45°. Les mouvements longitudinal - montée/ descente sont motorisés. Un système électronique de contrôle de vitesse, réglable par l'opérateur, gère le mouvement longitudinal de la tête.

ACCESSOIRES: Bac amovible de collecte eau; Pompe submerge pour le refroidissement du disque; Jeu de clefs de service; 2 supports latéraux fixes; 1 rallonge à rouleaux; Butée latérale; Système d'incrémentation de passe.

EN OPTION: Rallonges à rouleaux supplémentaires; Disco diamanté; PLC pour la coupe incrémentée; Laser marque coupe; équerre mécanique.

ARTICOLO ITEM ARTICLE	MOD	 mm	 RPM	 kW - Volt	 mm	 mm	 mm	 cm (L-B-H)	 Kg	PREZZO PRICE PRIX €
150200	FRESA MANTA 250 automatica	450 - 40	2800	4 - 400*	2700	200	150	342x102x140	560	13.100,00
150201	FRESA MANTA 250 automatica	450 - 40	2800	5,5 - 400*	2700	200	150	342x102x140	560	14.000,00
150202	FRESA MANTA 250 automatica	450 - 40	1400	5,5 - 400*	2700	200	150	342x102x140	560	14.400,00
150251	FRESA MANTA 300 automatica	450 - 40	2800	5,5 - 400*	3200	200	150	395x102x140	660	16.200,00
150252	FRESA MANTA 300 automatica	450 - 40	1400	5,5 - 400*	3200	200	150	395x102x140	660	16.800,00

*IT Disponibile in versione monofase - 2,2 kw.2800/1400 RPM. *EN Single phase is also available - 2.2 kW - 2800/1400 RPM. *FR Disponible monophasé 2.2 kW - 2800/1400 RPM

MANTA 200-250-300 ECO

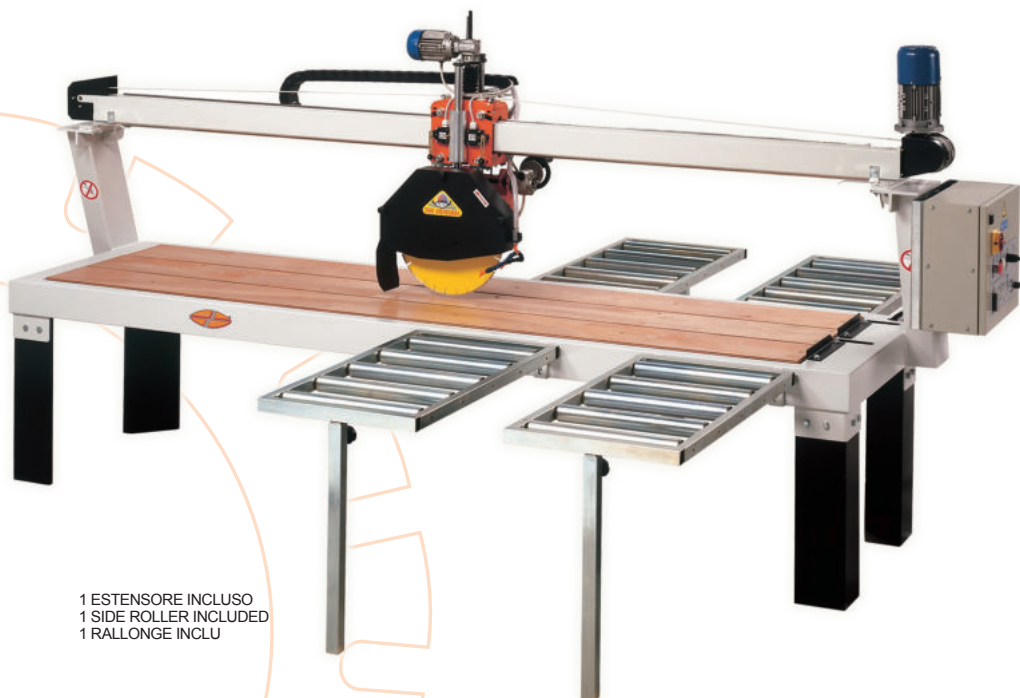

1 ESTENSORE INCLUSO
1 SIDE ROLLER INCLUDED
1 RALLONGE INCLU

VERSIONE MANUALE
MANUAL VERSION
VERSION MANUELLE



IT
Economica, semplice e robusta. Adatta sia al piccolo laboratorio che alla grande industria. Banco in legno marino. Possibilità di taglio da 90° a 45° per ogni tipo di materiale lapideo. Disponibile in due versioni: manuale e automatica.

ACCESSORI: Pompa; Set di chiavi di servizio; Estensore a rulli; Battuta laterale; Sistema per tagli a incremento.

OPZIONALE: Ulteriori estensori; Disco diamantato; Laser segna-taglio; Squadra meccanica

EN
Automatic Stone Slab Saw - Available in two versions: manual and automatic. Heavy-duty, inexpensive and easy to run. Provided with a plywood bench. Suitable both for small workshops and big industries processing any kind of stone material. Cuts from 90 to 45°.









ACCESSORIES: Pump; Set of servicing wrenches; Roller side table; Side stop; System for incremental cuts.

OPTIONALS: Extra roller extensions; Diamond cutting Blade; Laser pointer; Mechanic square.

FR
Débiteuse automatique - Économique, simple et robuste, employée dans les petits marbreries. Disponible dans 2 versions: manuelle et automatique. Le banc est en bois marin. Possibilité de couper de 90° jusqu'à 45° pour toutes matières lithiques.

ACCESSOIRES: Pompe; Jeu de clés de service; Rallonge à rouleaux; Butée Système d'incrément de passe.

EN OPTION: Rallonges supplémentaires; Disque diamant; Laser marque-coupe; Équerre mécanique.

ARTICOLO ITEM ARTICLE	MOD	 mm	 RPM	 kW - Volt	 mm	 mm	 mm	 cm (L-B-H)	 Kg	PREZZO PRICE PRIX €
150552	FRESA MANTA 200 ECO manuale	450 - 30	2800	4 - 400*	2000	250	150	290x91x121	340	8.390,00
150553	FRESA MANTA 200 ECO manuale	450 - 30	1400	4 - 400*	2000	250	150	290x91x121	340	8.750,00
150550	FRESA MANTA 200 ECO automatica	450 - 30	2800	4 - 400*	2000	250	150	314x91x121	360	9.390,00
150551	FRESA MANTA 200 ECO automatica	450 - 30	1400	4 - 400*	2000	250	150	314x91x121	360	9.760,00
150602	FRESA MANTA 250 ECO manuale	450 - 30	2800	4 - 400*	2500	250	150	340x91x121	395	8.790,00
150603	FRESA MANTA 250 ECO manuale	450 - 30	1400	4 - 400*	2500	250	150	340x91x121	395	9.100,00
150601	FRESA MANTA 250 ECO automatica	450 - 30	2800	4 - 400*	2500	250	150	364x91x121	410	9.740,00
150600	FRESA MANTA 250 ECO automatica	450 - 30	1400	4 - 400*	2500	250	150	364x91x121	410	9.860,00
150652	FRESA MANTA 300 ECO manuale	450 - 30	2800	4 - 400*	3000	250	150	390x91x121	450	10.030,00
150653	FRESA MANTA 300 ECO manuale	450 - 30	1400	4 - 400*	3000	250	150	390x91x121	450	10.400,00
150651	FRESA MANTA 300 ECO automatica	450 - 30	2800	4 - 400*	3000	250	150	414x91x121	470	10.700,00
150650	FRESA MANTA 300 ECO automatica	450 - 30	1400	4 - 400*	3000	250	150	414x91x121	470	11.750,00

*IT Disponibile in versione monofase 2,2 kw.2800/1400 RPM. *EN Single phase also available - 2.2 kW - 2800/1400 RPM. *FR Disponible monophase 2.2 kW - 2800/1400 RPM

MANTA COMPACT 200-250-300

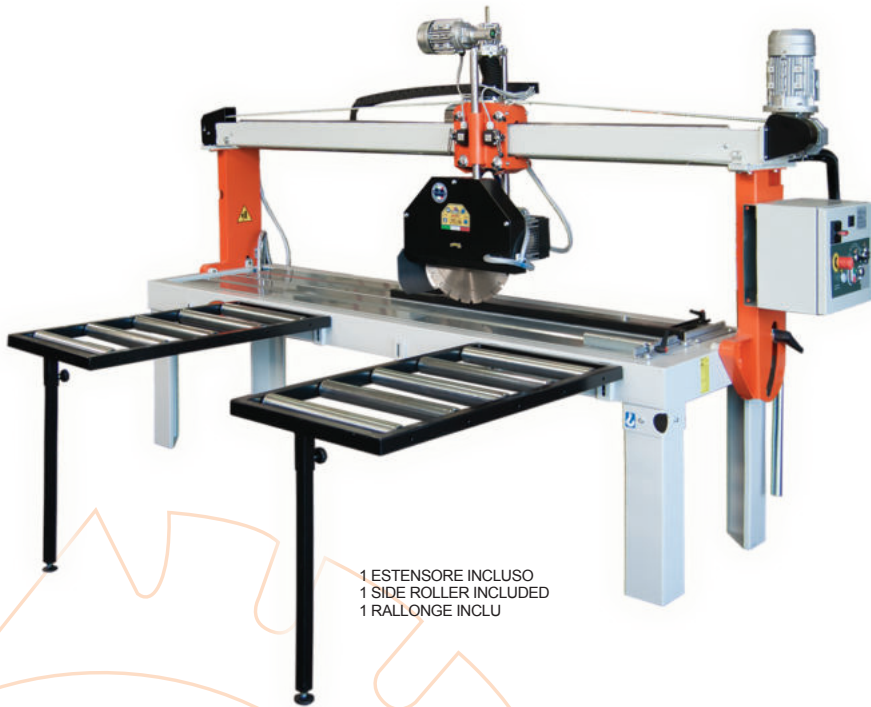

1 ESTENSORE INCLUSO
1 SIDE ROLLER INCLUDED
1 RALLONGE INCLU

VERSIONE MANUALE
MANUAL VERSION
VERSION MANUELLE



IT
Economica semplice e robusta. Adatta al piccolo laboratorio o per la grande produzione artigianale. Struttura e banco di lavoro in ferro. Possibilità di taglio da 90° a 45° per ogni tipo di materiale lapideo. Scorrimento gruppo di taglio su trave in acciaio strutturale. L'inclinazione dell'intero gruppo di taglio avviene tramite 2 leve (1 a destra e 1 a sinistra). La macchina è disponibile in 2 versioni (avanzamento e sollevamento testa): manuale e automatica. Gambe angolari.

ACCESSORI: Pompa sommersa per il raffreddamento del disco; 1 estensore laterale a rulli; 1 battuta laterale; Chiavi di servizio.

OPZIONALI: Disco di taglio; Estensori aggiuntivi; Laser segna-taglio; Squadra meccanica.

EN
Rugged, inexpensive and simple machine. Framework and table in steel; cutting head sliding on structural steel beam; Angle legs; tilting head for 45 degree angle cuts. Inclination of the whole cutting unit by means of two hand-levers. Available in two versions (head travel and rise/fall): manual and automatic.









ACCESSORIES: Water pump to cool the blade; 1 side roller table; 1 side stop; Set of servicing wrenches.

OPTIONALS: Cutting blade; Extra roller tables; Laser pointer; Mechanic square.

FR
Economique, robuste et simple à utiliser. Adapte pour les travaux soit dans les petites marbreries, soit dans les grandes industries. Châssis et tablier en acier. Possibilité de coupe de 90° à 45° pour n'importe quelle pierre. Déplacement de l'unité de coupe sur poutre en acier structural; disponible dans 2 versions (déplacement et plongée de la tête de sciage); manuelle et automatique. Jambes à angles.

ACCESSOIRES: Pompe à eau de refroidissement du disque; 1 rallonge à rouleaux; 1 butée; Jeu de clefs de service.

EN OPTION: Disque; Rallonges supplémentaires; Laser marque-coupe; équerre mécanique.

ARTICOLO ITEM ARTICLE	MOD	 mm	 RPM	 kW - Volt	 mm	 mm	 mm	 mm	 cm (L-B-H)	 Kg	PREZZO PRICE PRIX €
150900	FRESA MANTA 200 COMPACT MANUALE	350 - 25.4	2800	3 - 400*	2000	250	110	290x91x121	237	6.390,00	
150911	FRESA MANTA 200 COMPACT MANUALE	450 - 30	1400	4 - 400*	2000	250	150	290x91x121	290	6.600,00	
150920	FRESA MANTA 200 COMPACT SEMI AUTOMATICA	350 - 25.4	2800	3 - 400*	2000	250	110	314x91x121	250	7.260,00	
150931	FRESA MANTA 200 COMPACT SEMI AUTOMATICA	450 - 30	1400	4 - 400*	2000	250	150	314x91x121	305	7.450,00	
150901	FRESA MANTA 250 COMPACT MANUALE	350 - 25.4	2800	3 - 400*	2500	250	110	340x91x121	260	6.800,00	
150912	FRESA MANTA 250 COMPACT MANUALE	450 - 30	1400	4 - 400*	2500	250	150	340x91x121	315	7.030,00	
150921	FRESA MANTA 250 COMPACT SEMI AUTOMATICA	350 - 25.4	2800	3 - 400*	2500	250	110	364x91x121	280	8.200,00	
150932	FRESA MANTA 250 COMPACT SEMI AUTOMATICA	450 - 30	1400	4 - 400*	2500	250	150	364x91x121	335	8.400,00	
150902	FRESA MANTA 300 COMPACT MANUALE	350 - 25.4	2800	3 - 400*	3000	250	110	390x91x121	300	8.600,00	
150913	FRESA MANTA 300 COMPACT MANUALE	450 - 30	1400	4 - 400*	3000	250	150	390x91x121	350	8.800,00	
150922	FRESA MANTA 300 COMPACT SEMI AUTOMATICA	350 - 25.4	2800	3 - 400*	3000	250	110	414x91x121	315	9.500,00	
150933	FRESA MANTA 300 COMPACT SEMI AUTOMATICA	450 - 30	1400	4 - 400*	3000	250	150	414x91x121	365	9.700,00	

*IT Disponibile in versione monofase - 2.2 kW - 2800/1400 RPM. *EN Single phase also available - 2.2 kW - 2800/1400 RPM *FR Disponible monophasé 2.2 kW - 2800/1400 RPM

SCORPIONE



INCLUSO, INCLUDED, INCLU

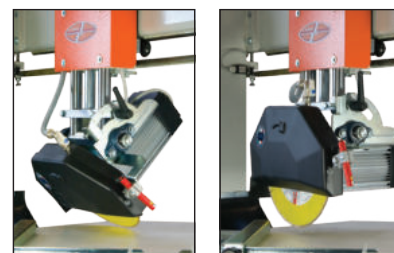

OPZIONALI / Optional / en option

ARTICOLO ITEM ARTICLE	MOD	PREZZO PRICE PRIX €
17F015	Gruppo foratrice verticale completa Drill unit Système de perçage	3.732,00

IT

Scorpione è una intestatrice per il taglio di lastre di marmo e granito in elementi di lunghezza ridotta o prestabilita. Il piano di lavoro a rulli è dotato di battuta di arresto per il taglio dei pezzi alla misura voluta. Il gruppo di taglio, scorre su speciali guide a cuneo in acciaio fresato, lungo l'asse di taglio, mentre per l'asse verticale scorre su alberi cromati e rettificati di grosso diametro. Disponibile in 2 versioni: manuale o automatica.

ACCESSORI: Battuta regolabile; 2 Rulliere laterali; Set di chiavi di servizio; Laser segna-taglio.

OPZIONALE: Testa con foretto; Disco di taglio.

EN

Scorpione is a squaring for cutting slab of marble and granite into elements of reduced length or predetermined. The work roller is equipped with stop for cutting the pieces to the extent desired. The cutting unit, slides on special guides wedge milled steel, along the cutting axis, while the vertical axis slides on chromed shafts and ground of large diameter. Two models available: manual or automatic.

ACCESSORIES: Stop; 2 Roller side tables; Battery laser pointer; Set of servicing wrenches.









OPTIONALS: Drilling Unit; Cutting blade.

FR

Scorpione est un sectionneur pour couper des plaques de marbre et de granit en éléments de longueur réduite ou prédéterminée. Le plan de travail à rouleaux est équipé de butée d'arrêt pour la coupe des pièces dans la mesure souhaitée. L'unité de coupe s'écoule sur des guides spéciales à coin en acier fraisé, le long de l'axe de coupe, tandis que le mouvement vertical se fait sur des arbres chromés et rectifié de grand diamètre. A machine est disponible en deux versions: manuelle ou automatique.

ACCESSOIRES: Butée; Tables à rouleaux; Laser marque-coupe; Jeu de clés de service.

EN OPTION: Système de perçage; Disque de coupe.

ARTICOLO ITEM ARTICLE	MOD	 mm	 RPM	 kW - Volt	 mm	 mm	 mm	 cm (L-B-H)	 Kg	PREZZO PRICE PRIX €
122002	SCORPIONE BASIC MONOFASE	350 - 25,4	2800	2,2-230*	700(90°)-600(45°)	140	110	185x133x187	400	9.600,00
122000	SCORPIONE BASIC	350 - 30	2800	4-400*	700(90°)-600(45°)	140	100	185x133x187	440	9.800,00
122003	SCORPIONE SA MONOFASE	350 - 25,4	2800	2,2-230*	700(90°)-600(45°)	140	100	185x133x187	440	11.300,00
122004	SCORPIONE SA	350 - 30	2800	4-400*	700(90°)-600(45°)	140	100	185x133x187	450	11.700,00
122011	SCORPIONE SA TRIFASE	350 - 30	1400	4-400*	700(90°)-600(45°)	140	100	185x133x187	450	11.950,00

*IT Voltaggio e potenze a richiesta. *EN Voltage and Power on Request. *FR Voltage et puissance sur demande.

MANTA JR BASIC

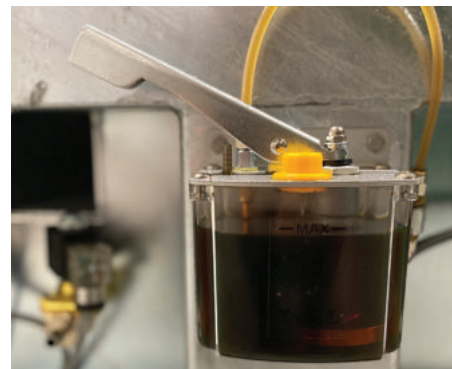
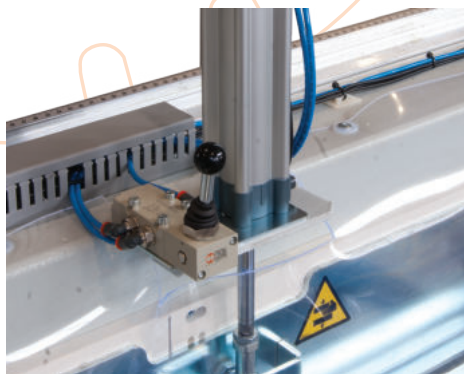
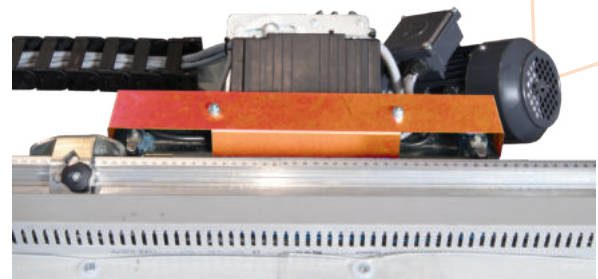
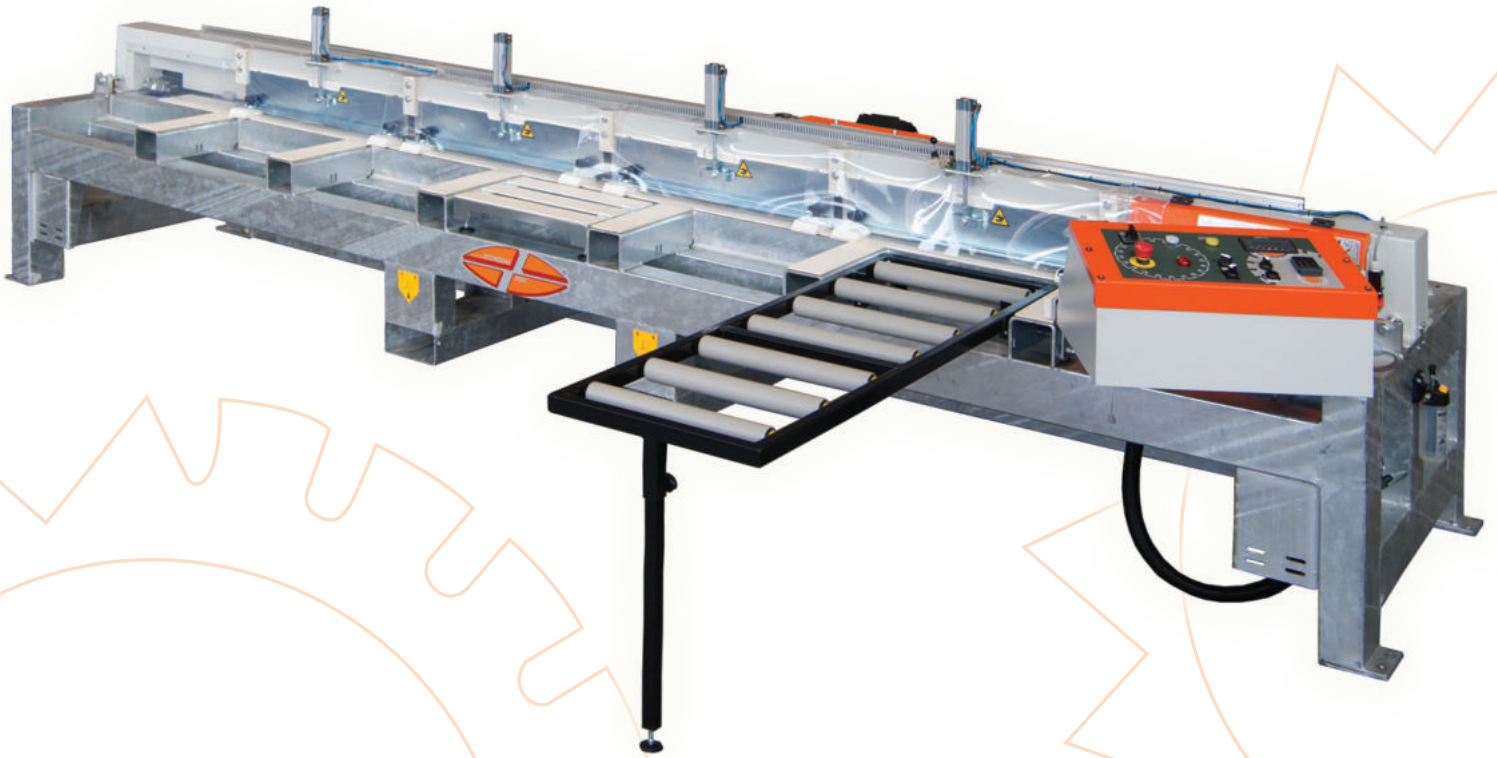

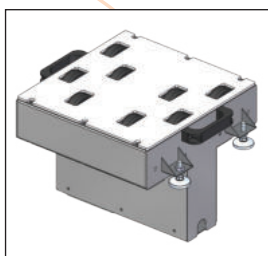

OPZIONALI / Optional / en option

ARTICOLO ITEM ARTICLE	MOD	PREZZO PRICE PRIX €
17M031	Pop up sollevamento lastra / Pop up rollers to lift slabs / Rouleaux de levage pour dalles	990,00
<small>*IT ulteriori accessori nella sezione dedicata Accessori frese *EN additional accessories in the section Accessories for saws / *FR accessoires supplémentaires dans la section Accessoires pour Débêteuses</small>		

IT
È la prima di una famiglia di macchine pensata per tagliare gli angoli in modo molto preciso. La sua struttura robusta, compatta e gli scorrimenti di precisione garantiscono una qualità di taglio eccezionale. La posizione del motore di taglio al di sotto del piano di lavoro fa sì che, nella maggior parte dei casi, la parte lucida del materiale sia rivolta verso il basso e a contatto col piano macchina ricoperto in gomma bianca. È corredata di 4 pistoni pneumatici per il blocco del materiale, può tagliare in entrambi i sensi con velocità regolabile ed è dotata di un sistema elettromeccanico per interrompere i tagli alla misura desiderata. L'inclinazione del disco è regolabile manualmente (+ - 5°), così come la battuta. Dotata di soffietti di protezione guide.

ACCESSORI: 6 Piedi di livellamento; Estensore con 7 rulli gommati; Taglio interrotto; Pianetto per pezzi piccoli; 2 Dispositivi per pezzi corti; 2 Dispositivi per pezzi sottili; Set di chiavi di servizio.

OPZIONALE: Disco di taglio; Estensori aggiuntivi; Rulliera per battiscopa; Kit pressore squadra laterale; Vasca con pompa; Training operatori.

EN
It is the first of a family of machines designed to cut corners very precisely. Its robust, compact structure and precision slides guarantee exceptional cutting quality. The position of the cutting motor below the work surface means that, in most cases, the shiny part of the material is facing downwards and in contact with the machine surface covered with white rubber. It is equipped with 4 pneumatic pistons for blocking the material, it can cut in both directions with adjustable speed and is equipped with an electromechanical system to interrupt the cuts to the desired size. The inclination of the disc is manually adjustable (+ - 5°), as is the stop. Equipped with guide protection bellows.







ACCESSORIES: 6 Levelling feet; Side table with 7 rubber covered rollers; Interrupted cut system; Table for small pieces; 2 Devices for short pieces; 2 Micro Clamps (for thin pieces); Set of servicing wrenches.

OPTIONALS: Cutting blade; Extra side tables; Mini roll extension; Ruler to adjust the length of cut; Water tray with pump; Operators' training.

FR
C'est le premier modèle d'une gamme de machines étudiées spécialement pour couper des angles dans une manière très précise. Sa structure robuste et compacte et ses coulisses de précision garantissent une qualité de coupe exceptionnelle. La position du moteur de coupe sous la surface de travail signifie que, dans la plupart des cas, la partie brillante du matériau est tournée vers le bas et en contact avec la surface de la machine recouverte de caoutchouc blanc. Il est équipé de 4 pistons pneumatiques pour bloquer le matériau, il peut couper dans les deux sens à vitesse variable et est équipé d'un système électromécanique pour interrompre les coupes à la taille souhaitée. L'inclinaison du disque est réglable manuellement (+ - 5°), de même que la butée. Equipé d'un soufflet de protection de guide.

ACCESSOIRES: 6 Pieds de nivellement; Table à 7 rouleaux avec revêtement en caoutchouc; Coupe interrompue; Table pour petits pièces; 2 Dispositifs pour pièces courtes; 2 Micro pinces (pour pièces minces); Jeu de clés de service.

EN OPTION: Disque de coupe; Rallonges Supplémentaires; Extension mini rouleau; Règle pour ajuster la longueur de coupe; Bac avec pompe; Training des opérateurs.

ARTICOLO ITEM ARTICLE	MOD	 mm	 RPM	 kW - Volt	 mm	 mm	 cm (L-B-H)	 Kg	PREZZO PRICE PRIX €
150813	MANTA JR BASIC - 45° testa fissa c/inverter	400 - 40	2800 max*	5,5 - 400	3500	60	483x120x115	1050	22.000,00
150803	MANTA JR BASIC	400 - 40	1400 max*	4 - 400	3500	60	483x120x115	1050	19.600,00

*IT Con inverter per la regolazione dei giri del disco. **Senza inverter. *EN With inverter for adjusting the disc rpm **Without inverter. *FR Avec onduleur pour ajuster le nombre de tours du disque **Sans onduleur

MANTA JR MULTIGRADO

MACCHINAPER TAGLI 45°/90°
SAW FOR 45°/90° ANGLE CUTS
DÉBITEUSE POUR COUPES À 45°/90°

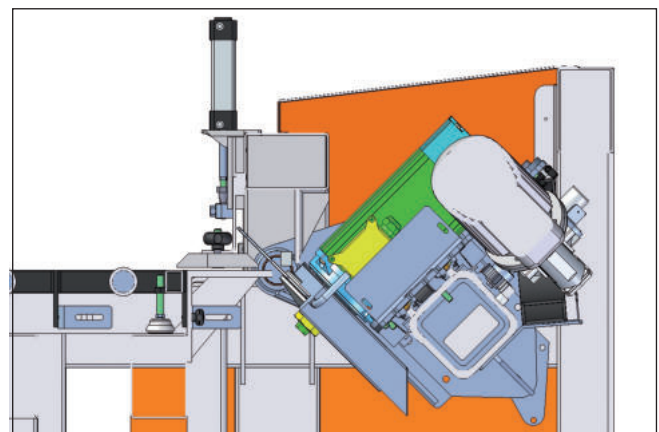
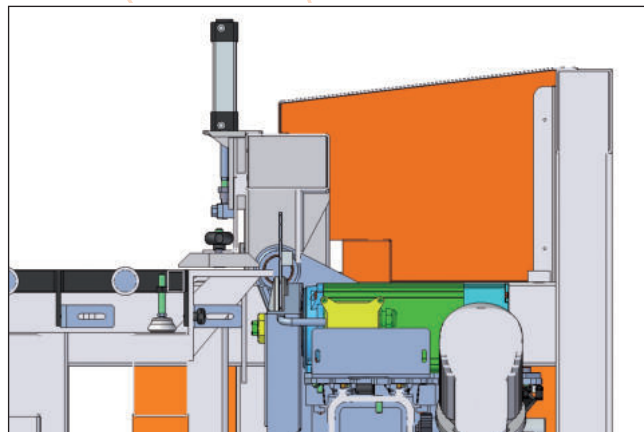

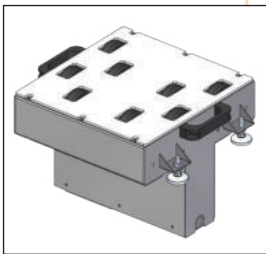
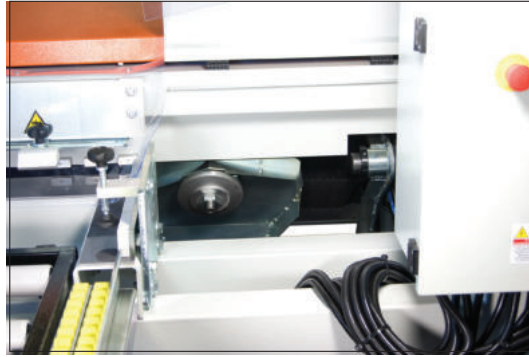
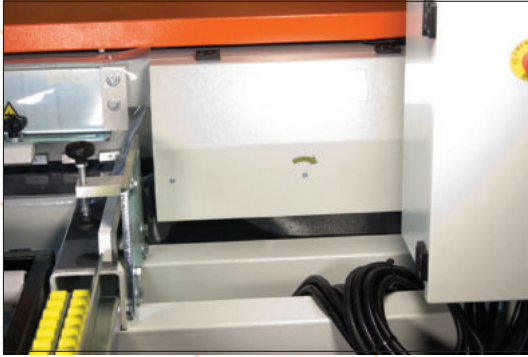

OPZIONALI / Optional / en option

ARTICOLO ITEM ARTICLE	MOD	PREZZO PRICE PRIX €
17M031	Pop up sollevamento lastra / Pop up rollers to lift slabs / Rouleaux de levage pour dalles	930,00
<small>*IT ulteriori accessori nella sezione dedicata Accessori frese *EN additional accessories in the section Accessories for saws / *FR accessoires supplémentaires dans la section Accessoires pour Débiteuses</small>		

IT

È il modello di punta di una gamma di macchine particolarmente studiate per tagliare angoli in modo molto preciso. La sua robusta e solida struttura è dotata di scivoli di precisione in grado di assicurare una qualità di taglio eccezionale. La posizione del motore di taglio al di sotto del piano di lavoro fa sì che, nella maggior parte dei casi, la parte lucida del materiale sia rivolta verso il basso e a contatto col piano macchina ricoperto di gomma bianca. Esso è dotato di un CNC che controlla il movimento di taglio e la velocità, l'inclinazione della lama da 90° a 45° passo passo di 1° ciascuna, la velocità di rotazione della lama diamantata e 4 pistoni pneumatici con 8 punti di contatto per il bloccaggio del materiale. È possibile tagliare i pezzi da 45 mm di larghezza minima (con appositi ganci).

ACCESSORI: 6 Piedi di livellamento; Estensore con 7 rulli gommati; Rulliera per battiscopa; 2 Dispositivo pezzi sottili; 2 Dispositivo pezzi corti; Kit pressore squadra laterale; Pianetto per pezzi piccoli; Set di chiavi di servizio.

OPZIONALI: Disco di taglio; Estensori aggiuntivi; Vasca con pompa; Training operatori.

EN

It's the top quality model of a range of machines especially studied for cutting corners in a very precise way. Its rugged, solid structure equipped with precision slides can assure an exceptional cut quality. The position of the cutting motor below the work surface means that, in most cases, the shiny part of the material is facing downwards and in contact with the machine bench covered with white rubber. It is equipped with a CNC controlling the cutting movement and speed, the blade tilting from 90° to 45° step by step of 1° each, the diamond blade rotation speed and 4 pneumatic pistons with 8 contact points for blocking the material. It is possible to cut pieces of 45 mm minimum width (with appropriate clamps).

ACCESSORIES: 6 Leveling feet/Side table with 7 rubber covered rollers/Mini roll extension/2 Micro Clamps (for thin pieces) 2 Devices for short pieces Ruler to adjust the length of cut Table for small pieces Set of servicing wrenches.







OPTIONALS: Cutting blade; Extra side tables; Water tray with pump; Operators' training.

FR

C'est le modèle de qualité plus élevée à l'intérieur d'une gamme de machines étudiées spécialement pour couper des angles dans une manière très précise. Sa structure robuste et compacte dotée de glissements de précision peut garantir une qualité de coupe exceptionnelle. La position du moteur de coupe sous la surface de travail signifie que, dans la plupart des cas, la partie brillante du matériau est tournée vers le bas et en contact avec la surface de la machine recouverte de caoutchouc blanc. Elle est équipée d'un CNC qui contrôle le mouvement et la vitesse de coupe, l'inclinaison du disque de 90° à 45° pas-à-pas de 1° chacun, la vitesse de rotation du disque diamanté et 4 pistons pneumatiques avec 8 points de contact pour bloquer le matériel. Il est possible de couper des pièces de 45 mm de largeur minimum (avec des presseurs appropriés).

ACCESSOIRES: 6 Pieds de nivellement; Table à 7 rouleaux avec revêtement en caoutchouc; Extension mini rouleau; 2 Micro pinces (pour pièces minces); 2 Dispositifs pour pièces courtes; Règle pour ajuster la longueur de coupe; Table pour petits pièces; Jeu de clés de service.

EN OPTION: Disque de coupe; Rallonge supplémentaires; Bac avec pompe; Training des opérateurs.

ARTICOLO ITEM ARTICLE	MOD	 mm	 RPM	 kW - Volt	 mm	 mm	 cm (L-B-H)	 Kg	PREZZO PRICE PRIX €
150807	FRESA MANTA JR MULTIGRADO	400 - 40	2800	5,5 - 400	3500	60	485x120x115	1100	25.300,00

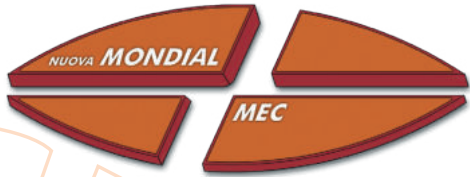

Accessori Frese



Accessories for Saws



Accessoires pour Débiteuses

IT Estensore a rulli per fresa
EN Roller bench extension for Saw
FR Rallonge à rouleaux

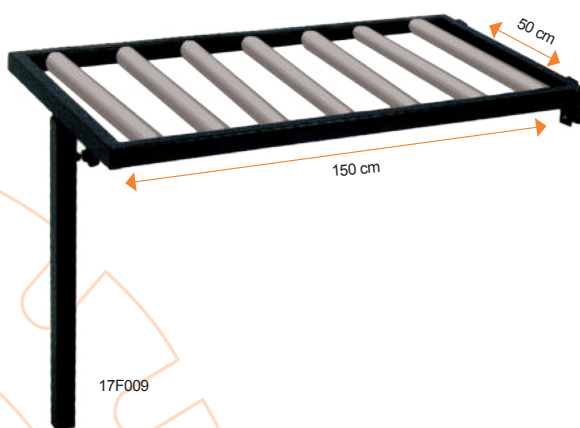

ESTENSORE A RULLI PER FRESA

ARTICOLO ITEM ARTICLE	UTILIZZABILE SU AVAILABLE ON DISPONIBLE SUR	PESO WEIGHT POIDS Kg	PORTATA MAX MAXI LOADING PORTÉE MAXI Kg	PREZZO PRICE PRIX €
17F001	AUTOMATICA - SPECIAL	40	330	700,00
17F009	MANTA JR - n° 7 rulli gommati MANTA JR - n° 7 rubber covered rolls MANTA JR - n° 7 rouleaux couverts de caoutchouc	30	56	690,00
17F010*	MANTA JR - n° 9 rulli gommati MANTA JR - n° 9 rubber covered rolls MANTA JR - n° 9 rouleaux couverts de caoutchouc	40	90	810,00

**IT Con due piedi. *EN With two legs. *FR Avec deux pieds*

IT Laser
EN Laser
FR Laser

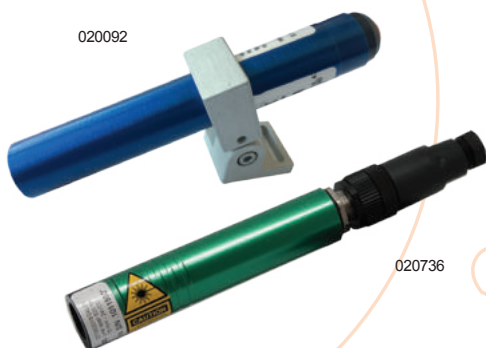

LASER

ARTICOLO ITEM ARTICLE	UTILIZZABILE SU AVAILABLE ON DISPONIBLE SUR	TIPO TYPE TYPE	mW	PREZZO PRICE PRIX €
020092	SPECIAL - ECO - COMPACT	a batteria	1	240,00
020736	POKER JUMBO - POKER 3500 - SPECIAL ECO - COMPACT	Diodo Verde	15	740,00
17M038	LASER ELETTRICO COMPLETO (M. KERAMIK)	Verde	15	800,00
021080	LASER PUNTO ROSSO			675,00

IT Mensola
EN Bracket
FR Support



MENSOLA

ARTICOLO ITEM ARTICLE	UTILIZZABILE SU AVAILABLE ON DISPONIBLE SUR	PREZZO PRICE PRIX €
04FS000T00	AUTOMATICA - SPECIAL	82,00



IT
Pigna remotata

EN
Keyboard for
remote control

FR
boîtier de commande
à distance

PIGNA REMOTATA

ARTICOLO ITEM ARTICLE	UTILIZZABILE SU AVAILABLE ON DISPONIBLE SUR	PREZZO PRICE PRIX €
020093	Assi X - Z X - Z Axis Axes X - Z	570,00
020658	Assi X - Y - Z Poker Poker X - Y - Z Axis Axes X - Y - Z Poker	570,00

IT
Squadra Meccanica

EN
Mechanic square

FR
Équerre mécanique

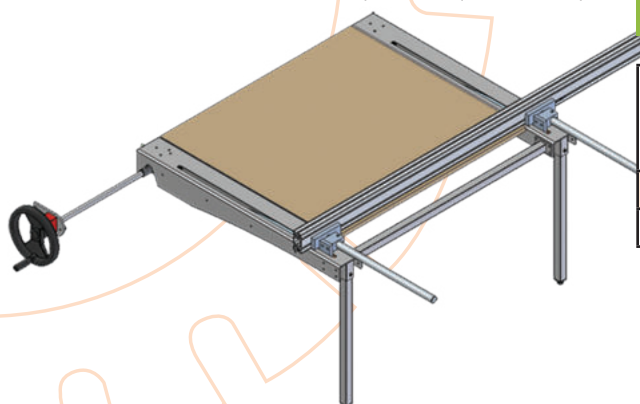

SQUADRA MECCANICA

ARTICOLO ITEM ARTICLE	UTILIZZABILE SU AVAILABLE ON DISPONIBLE SUR	PREZZO PRICE PRIX €
17F023	AUTOMATICA-SPECIAL	3.386,00
17F030	LX-LX SA PLUS-ECO-COMPACT	3.640,00

IT
Vasca estraibile per
raccolta acqua di
raffreddamento del
disco. Provvista di
pompa.

EN
Movable water tray
collecting the water,
provided with pump

FR
Bac amovible
de collecte eau,
pourvue de pompe

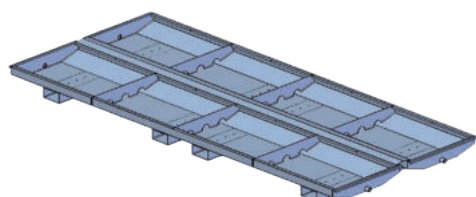

VASCA ESTRAIBILE

ARTICOLO ITEM ARTICLE	UTILIZZABILE SU AVAILABLE ON DISPONIBLE SUR	PESO WEIGHT POIDS Kg	PREZZO PRICE PRIX €
04F301S003T00*	SPECIAL 250	-	645,00
04F302S003T00*	SPECIAL 300	-	780,00
17F026GALV	MANTA JR	140	1.900,00

*IT Fornita senza pompa. *EN Supplied without pump. *FR Fournie sans pompe.

INVERTER PER REGOLAZIONE RPM DISCO

IT
Inverter lama

EN
Blade RPM adjustment Inverter

FR
Inverseur pour réglage RPM du disque

ARTICOLO ITEM ARTICLE	UTILIZZABILE SU AVAILABLE ON DISPONIBLE SUR	PREZZO PRICE PRIX €
17F042	POKER JUMBO AUTOMATICA (8 KW)	2.520,00
17F048	POKER JUMBO BASIC (5.5 KW)	2.400,00
17F070	POKER JUMBO BRUSHLESS (8KW)	2.520,00

ACCESSORI PER MANTA JR

IT
Accessori per Manta JR

EN
Accessories for Manta JR

FR
Accessoires pour manta JR

ARTICOLO ITEM ARTICLE	DESCRIZIONE DESCRIPTION DESCRIPTION	PREZZO PRICE PRIX €
17F014	Rulliera listelli mini roll / Mini roll extension / Rallonge mini rouleaux	510,00
17F021	Pianetto pezzi piccoli / Table for small pieces / Table pour petites pièces	340,00
04F600ST05100	Pattino pressore extra piccolo / Extra small Clamp / Serre-joint extra petit	50,00
18F041	Pattino pressore / Standard Clamp / Serre-joint Standard	98,00

